

SPRAWOZDANIA ARCHEOLOGICZNE

INSTYTUT ARCHEOLOGII I ETNOLOGII POLSKIEJ AKADEMII NAUK



Archaeological Reports
72
2
Archäologische Berichte

KRAKÓW 2020

**SPRAWOZDANIA
ARCHEOLOGICZNE**

INSTYTUT ARCHEOLOGII I ETNOLOGII
POLSKIEJ AKADEMII NAUK

SPRAWOZDANIA ARCHEOLOGICZNE



KRAKÓW 2020

Copyright © by the Authors and Instytut Archeologii i Etnologii Polskiej Akademii Nauk 2020

Editor

PIOTR WŁODARCZAK, wlodarczak.piotr@gmail.com

Editorial Secretary

ANNA RAUBA-BUKOWSKA, sprawozdania.archeologiczne@gmail.com

Editorial Committee

SYLWESTER CZOPEK, SŁAWOMIR KADROW, JANUSZ KRUK (CHAIRMAN), JAN MACHNIK, SARUNAS MILISAUSKAS, JOHANNES MÜLLER, JAROSLAV PEŠKA, ALEKSANDER SYTNIK, PRZEMYSŁAW URBAŃCZYK

All articles in this volume of *Sprawozdania Archeologiczne* obtained approval of the following specialists:

Makoto Arimura, Justyna Baron, Felix Biermann, Sebastian Brather, Igor Bruyako, Janusz Budziszewski, Kotera Chizuko, Alexandr Diachenko, Michał Dzik, Vladimir Erlikh, Mirosław Furmanek, Tomasz Gralak, Radosław Janiak, Andrzej Janowski, Paweł Jarosz, Sławomir Kadrow, Arkadiusz Koperkiewicz, Przemysław Makarowicz, Tomasz Nowakiewicz, Łukasz Oleszczak, Aleksander Paroń, Michał Pawleta, Tomasz Purowski, Joanna Pyzel, Antoinette Rast-Eicher, Vitaliy Sinika, Piotr Strzyż, Anita Szczepanek, Bartłomiej Szmoniewski, Maciej Trzeciecki, Stanisław Țerna, Andrzej Wiśniewski, Barbara Witkowska, Marcin Wołoszyn, Jakub Wrzosek, Marta Żuchowska

English proofreading

MARK TOUSSAINT

Technical Editor and Layout

JOANNA KULCZYŃSKA-KRUK

Centre for Mountains and Uplands Archaeology, Institute of Archaeology and Ethnology, Polish Academy of Sciences

Cover

So-called Światowit from Wolin. Photo by PAWEŁ SZCZEPANIK

Professor Jan Machnik. Photo by KRZYSZTOF TUNIA

Editor's Address

CENTRE FOR MOUNTAINS AND UPLANDS ARCHAEOLOGY, INSTITUTE OF ARCHAEOLOGY AND ETHNOLOGY, POLISH ACADEMY OF SCIENCES, 31-016 KRAKÓW, UL. SŁAWKOWSKA 17



Ministry of Science
and Higher Education
Republic of Poland

Volume financed by the Ministry of Science and Higher Education from the funds for science popularization activities, Contract Nr 651/P-DUN/2019

PL ISSN 0081-3834

DOI: 10.23858/SA/72.2020.2

Printed by

PARTNER POLIGRAFIA Andrzej Kardasz, Grabówka, ul. Szosa Baranowicka 77, 15-523 Białystok

Edition: 300 pcs.

Sprawozdania Archeologiczne is regularly listed in the: SCOPUS, CEJSH, ERIH Plus

CONTENTS

ARTICLES	11
Kathryn M. Hudson, Janusz Kruk, Sarunas Milisauskas Journeys of the Mind: Cognitive Landscapes, Symbolic Dialects, and Networked Identities in the European Neolithic	11
Aldona Kurzawska, Iwona Sobkowiak-Tabaka <i>Spondylus</i> shells at prehistoric sites in Poland	41
Aleksandra Gawron-Szymczyk, Dagmara Łaciak, Justyna Baron To smooth or not to smooth? A traceological and experimental approach to surface processing of Bronze and Iron Age ceramics	67
Katarzyna Trybała-Zawiślak The Chotyńiec agglomeration and its importance for interpretation of the so-called Scythian finds from south-eastern Poland	87
Bartłomiej Szymon Szmoniewski Roman and Early Byzantine finds from the Japanese Archipelago – a critical survey	117
Paweł Szczepanik Comparative analysis of early medieval anthropomorphic wooden figurines from Poland. Representations of gods, the deceased or ritual objects?	143
FIELD SURVEY AND MATERIALS	169
Marcin Wąs, Lucyna Domańska, Seweryn Rzepecki Middle Palaeolithic flint artefacts from Central Poland. Case study of the site of Polesie 1, Łowicz district, Łódź voivodship	169

Janine Mazanec, Susanne Hummel, Thomas Saile

“Raptus Sabinae?” complemented: molecular genetic studies on a female *calvarium* of the *Bandkeramik* settlement of Rovantsi in Volhynia (UA) 201

Guram Chkhatarashvili, Valery Manko, Amiran Kakhidze, Ketevan Esakiya, Maia Chichinadze, Marianna Kulkova, Mikhail Streltsov

The South-East Black Sea coast in the Early Holocene period (according to interdisciplinary archaeological investigations at the Kobuleti site) 213

Weronika Skrzyniecka

Textile impressions on the Trypillia culture pottery from Ogród and Vertebea Cave sites in Bilcze Żłote 231

Barbara Witkowska, Janusz Czebreszuk, Barbara Gmińska-Nowak, Tomasz Goslar, Marzena Szmyt, Tomasz Ważny

The cemetery of the Globular Amphora culture community at the Żłota-Gajowizna site in the light of radiocarbon analysis and dendrochronology 259

Monika Bajka, Marek Florek

Żłota culture grave from Kleczanów, Sandomierz District, Świętokrzyskie Voivodeship 285

Paweł Jarosz, Jerzy Libera

Early Bronze Age barrow in Jawczyce, site 1, Wieliczka Foothills, Lesser Poland 307

Marcin Burghardt

Classification and chronology of the collection of arrowheads from the ash-hill found in the hillfort of the Scythian Cultural Circle in Chotyńiec, site 1, Jarosław district 327

Sergey B. Valchak, Sergey D. Lysenko, Nikolai Yu. Gorbol, Sergey N. Razumov, Nikolai P. Telnov, Vitalij S. Sinika

Graves of the beginning of the Early Iron Age in barrow 1 of the “Rybkhoz” (“Fish farm”) Group in the Lower Dniester region 357

Erwin Gáll, Florin Mărginean

Archaeological Discoveries Linked to the “First Generation” of the Avar Conquerors Living East of the Tisa During the 6th-7th Centuries. The Grave Cluster in Nădlac – Site 1M 373

Tomasz Dzieńkowski, Marcin Wołoszyn, Iwona Florkiewicz, Radosław Dobrowolski, Jan Rodzik, Irka Hajdas, Marek Krąpiec

Digging the history. Absolute chronology of the settlement complex at Czermno-Cherven’ (eastern Poland). Research status and perspectives 409

Ewa Anna Lisowska, Sylwia Rodak	
A hillfort complex in Mysłibórz in the Sudety Mountains	467
Hanna Olczak, Dariusz Krasnodębski, Roman Szlązak, Joanna Wawrzениuk	
The Early Medieval Barrows with Kerbstones at the Leśnictwo Postołowo Site 11 in the Białowieża Forest (Szczekotowo Range)	511
Beata Miazga, Sylwia Rodak, Jeannette Jacqueline Lucejko, Erika Ribechini	
A unique early medieval pendant (kaptorga) from Opole Groszowice (Silesia, SW Poland) in the light of interdisciplinary archaeometric studies	539
Jakub Niebylski	
The remains of the “Battle of Kraków”, fought during World War I, as exemplified by site Sadowie-Kielnik 1, Kraków district	555
DISCUSSIONS AND POLEMICS	585
Denys Grechko	
Chronological schemes of the Late Hallstatt period (HaD) in Central Europe: new opportunities for the synchronization and refinement of dates	585
REVIEWS AND SHORT REVIEW NOTES	355
Joanna Wawrzениuk	
(Review) Andrzej Bronisław Pankalla, Konrad Kazimierz Kośnik, <i>Indygeniczna psychologia Słowian. Wprowadzenie do realnej nauki</i> . Kraków 2018: Universitas, 216 pp.	607
Halina Taras	
(Review) Katarzyna Trybała-Zawiślak, <i>Wczesna epoka żelaza na terenie Polski południowo-wschodniej – dynamika zmian i relacje kulturowe (The Early Iron Age in south-eastern Poland – dynamics of changes and cultural relations)</i> . Rzeszów 2019: Wydawnictwo Uniwersytetu Rzeszowskiego. ISBN 978-83-7996-726-1. 402 pp.	615
Information for Contributors	621

Sprawozdania Archeologiczne is regularly listed in the International Current Awareness Service: Anthropology. Selected material is indexed in the International Bibliography of social and Cultural Anthropology.

Indexed in:

IBZ – International Bibliography of Periodical Literature

IBZ – CD-ROM



Dedicated to Professor Jan Machnik for His 90th Birthday

DISCUSSIONS AND POLEMICS

Denys Grechko¹

CHRONOLOGICAL SCHEMES OF THE LATE HALLSTATT PERIOD (HaD) IN CENTRAL EUROPE: NEW OPPORTUNITIES FOR THE SYNCHRONIZATION AND REFINEMENT OF DATES

ABSTRACT

Grechko D. 2020. Chronological schemes of the Late Hallstatt period (HaD) in Central Europe: new opportunities for the synchronization and refinement of dates. *Sprawozdania Archeologiczne* 72/2, 585-605.

Unification of regional chronological schemes is one of the key issues in Early Iron Age archaeology. The main markers of the Late Hallstatt period are Scythian arrowheads and antique imports. Biconical glass beads, produced at the Yahorlyk settlement (in the first third of the VIth century BC), were found in the Eastern European Forest-Steppe and in the area of the Tarnobrzeg Lusatian Culture. This period is synchronised with the HaD1 of Central Europe, phase III/1 of the TLC and the late group of burials of the second phase of the Kelermes period. Its final phase is associated with the so-called "Scythian invasions" in Central Europe, which led to the decline of the Chotyniec agglomeration, West-Podolian and East-Podolian groups. A few TLC complexes of the Grodzisko Dolne, site 22, can be dated somewhat later, to the middle or second half of the VIth century BC (HaD2). Also, at this time, the Pomeranian population appeared in the south-eastern area of the Lusatian tribes and a new culture model (post Lusatian-Pomeranian stage) arose.

Keywords: Central Europe, Tarnobrzeg Lusatian Culture, East European Forest-Steppe groups, biconical glass beads, Late Hallstatt period, chronology

Received: 24.06.2020; Revised: 10.08.2020; Accepted: 11.11.2020

¹ Institute of Archaeology of National Academy of Sciences of Ukraine, Geroiv Stalingrada 12, 04210 Kyiv, Ukraine; ukrspadshina@ukr.net; <https://orcid.org/0000-0003-3613-795X>

INTRODUCTION

The combination of regional chronological schemes into a single transregional chronology is one of the key issues in studies of the European Iron Age. Separate finds and entire complexes of the Early Scythian material culture in the middle of the VII – the middle of VI century BC are known throughout the wide territory of Northern Eurasia, in the areas of distribution of various cultural entities, which gives certain opportunities for the synchronization of local chronological schemes.

Based on dates obtained for complexes with glass beads, this paper deals with the chronological correlation of complexes dating to the Early Scythian time of the south of Eastern Europe and the Tarnobrzeg Lusatian Culture (TLC). All information about the finds of biconical glass beads on the territory of Europe in the Late Hallstatt period was collected. To clarify their dating, complexes that contained reliable chronological indicators (first of all, antique amphorae) were selected. Burials of the Eastern European Forest-Steppe can be attributed to the second phase of the Kelermes period (first third of the VI century BC). Comparison of these complexes to the materials from the TLC revealed the difference in their dating. Transferring the “Scythian” dates to the Lusatian complexes made possible the clarification of their dating within the period III/1 TLK. The linking of other data (arrowheads, pins, nail-shaped earrings) enabled the synchronization of the chronological schemes of Eastern and Central Europe in the Late Hallstatt period (HaD).

Recently, Sylwester Czopek developed the chronology and periodization of the TLC, which were successfully synchronized with the Hallstatt chronology and the Cimmerian and Scythian horizons (Czopek *et al.* 2018, 128). In recent years, data (from Modlnica, Grzęska *etc.*), which help to clarify the dating of both individual complexes of the TLC (phase III/1) and the settlements of the Chotyniec agglomeration, have emerged.

A prominent place in archaeological research has been rightfully occupied by radiocarbon dating. It should be noted that for the Hallstatt period, its use does not always give a positive result. Sylwester Czopek has already pointed out the incorrect radiocarbon dating of the lower part of the rampart at the Chotyniec hillfort (date calibration clearly indicated the IX century BC) and the fact that two broad dates (2680±40 BP, 2470±50 BP) from the Hrushovychi settlement were the results of the alignment of the calibration curve during the Central European Early Iron Age – the so-called Hallstatt gap (*ca.* 800-400 BC; Czopek *et al.* 2018, 197). Therefore, archaeological data and its methods should occupy a more central – and perhaps the foremost – position in the dating of complexes from this time.

The aim of this work is to search for opportunities to correlate the complexes dating to the Early Scythian time in the south of Eastern and Central Europe and the TLC, as a kind of “bridge” for synchronizing the chronological scheme of “Scythian” antiquities and Hallstatt period.

BICONICAL GLASS BEADS AS CHRONOLOGICAL MARKERS

Nowadays, the most accurate way to date the complexes of the Early Iron Age is via ancient Greek imports. A significant amount of such imports (pottery and adornments) began to spread among the nomads and settled tribes of the European Forest-Steppe from the end of the VII to the first third of the VI century BC, in connection with the intensification of Greek activity at the Berezan settlement and the work of craftsmen of the Yahorlyk settlement. In the course of working with the complexes, I drew attention to the biconical glass beads of various colours and shades that were found in burials and cultural layers – of both the cultural groups of the Dnieper and Dniester Forest-Steppes, and in the distribution area of the TLC in south-eastern Poland.

Polish specialists also drew attention to these imported products (Czopek 2011, 116, 129; Purowski 2012; 2015). The biconical glass beads of light green and honey colours were classified by Sylwester Czopek as type B (Czopek 2011, 116, 129), and by Tomasz Purowski as type I.VI (Purowski 2015, 225). Tomasz Purowski collected all the data about complexes with glass beads of this type: Modlnica, Dobkowice, Gorzyce, Grodzisko Dolne,



Fig. 1. Cultural groups and biconical glass beads from the sites of Central and Eastern Europe of the late Hallstatt period (HaD1). 1 – Solodka; 2 – Vovkivtsi; 3 – Poltava; 4 – Repiakhuvata Mohyla; 5 – Grzęska; 6 – Modlnica; 7 – Yahorlyk; 8 – Bilsk (Skorobir); 9 – Trynka; 10 – Spasivka; 11 – Wicina; 12 – Dobkowice; 13 – Gorzyce; 14 – Jasionka; 15 – Kęпно; 16 – Kosin; 17 – Lubnice; 18 – Sokolniki; 19 – Trzęsówka; 20 – Zabłotce; 21 – Shutnivtsi; 22 – Sokolets; 23 – Zozulyntsi. I – West-Podolian group; II – East-Podolian group; III – Kyiv-Cherkasy group; IV – Vorskla group

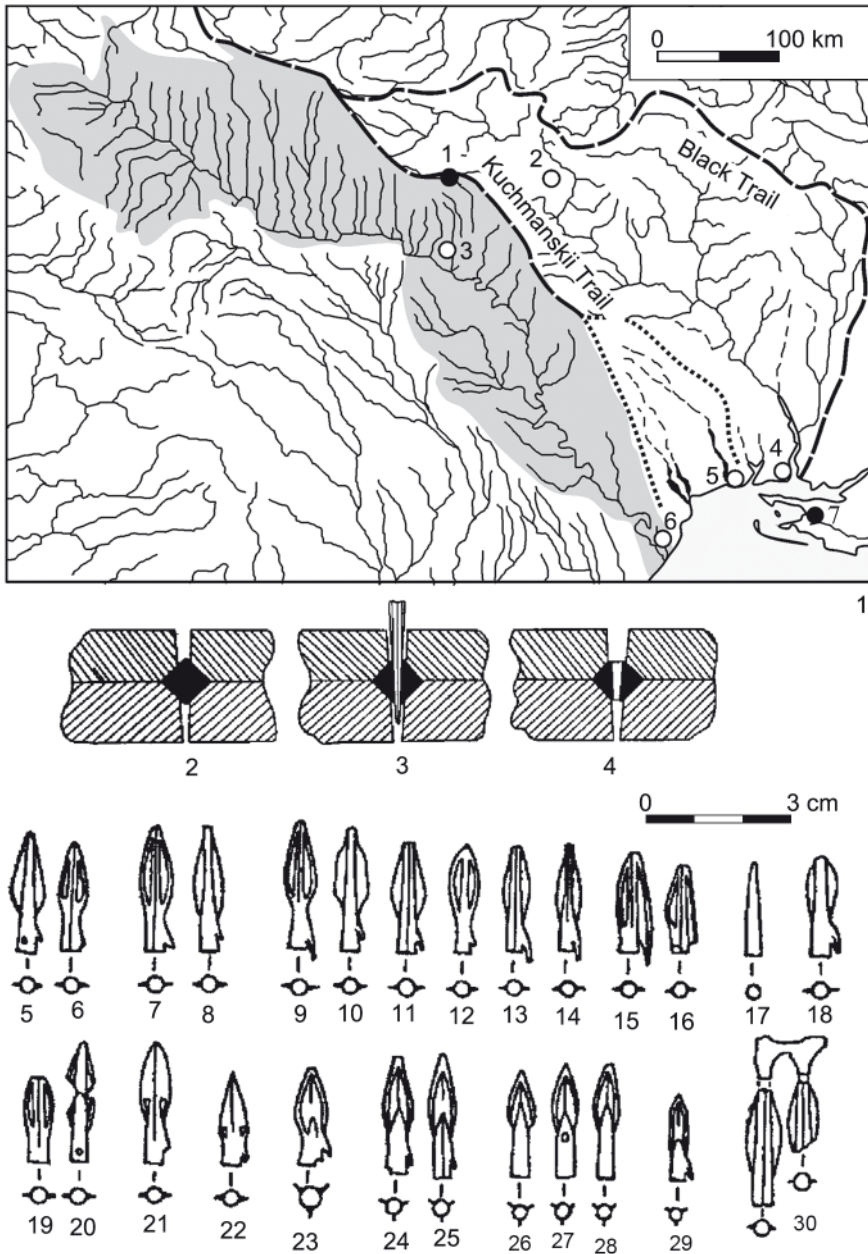

Fig. 2. Land routes and materials of the Yahoryk settlement. 1 – ancient roads of the interfluvium of the Dniester and Southern Bug rivers: (1 – Severynivka hillfort; 2 – Nemyriv; 3 – Hryhorivka hillfort; 4 – Olbia; 5 – Berezan; 6 – Nikonion; 7 – Yahorlyk; Boltryk *et al.* 2015); 2-4 – a probable method of making beads at the Yahorlyk settlement by pressing (Ostroverkhov 1978); 5-30 – arrowheads from the Yahorlyk settlement (Ostroverkhov 1981)

Grzęska, Jasionka, Kosin, Sokolniki, Trzęsówka, Zablotce, Wicina, Kępno, and Łubnice (Fig. 7: 3; Purowski 2015, 5, 226). In addition, analyses of the chemical composition of these items were also carried out (Samek *et al.* 2007; Purowski *et al.* 2015, 239-254).

Polish leading experts have dated such beads to the late part of the HaD period (Purowski 2012, 308, 330) or from the late part of HaD – the beginning of La Tène (LtA, phase III/2 TLK), corresponding to the second half of the VI – the first half of the V century BC. It should be noted that this group of complexes is chronologically homogeneous (Czopek 2011, 130-131; Czopek *et al.* 2016, 88). Similar dating of nail-shaped earrings, which often made up a single set with beads, places them earlier (Grzęska, burial No. 54 – Fig. 7: 1; Czopek *et al.* 2016, 88). Interestingly, Tomasz Purowski (Purowski 2015, 225-226) and Sylwester Czopek did not pay attention to the presence of similar beads at the Yahorlyk settlement and in well-dated burials of the Eastern European Forest-Steppe, which will be discussed in this article. Tomasz Purowski believes that the beads were made in the Northern Black Sea Region and entered the Odra and Vistula interfluvium through south-eastern Poland at the end of the Hallstatt period (Purowski 2015, 227). A team of authors of research dedicated to glass beads of the TLC connects the appearance of such beads with an oriental influence, which is called “Scythization” (Samek *et al.* 2007, 106).

An appeal to well-known complexes allows us to clarify the dating of this category of antique imports and, with their help, to attempt to synchronize chronological schemes – the Early Scythian and the TLC.

The location of the production of these beads is not in doubt among the majority of researchers – the Yahorlyk settlement in the bay of the same name in the Black Sea (Fig. 1: 7), between the Kinburn spit and the Yahorlytskyi Uhol Peninsula (Ostroverkhov 1978; Ilinskaya *et al.* 1980, 49; Shramko 2017, 375). Traces of glass melting (crucibles and cones filled with glass, and defective beads), as well as traces of the production of bronze products (arrowheads, adornments, *etc.*) were revealed in this settlement (Fig. 2: 2-30; Ostroverkhov 1978, 41-42; 1981, 26-30). Analysis of the ceramic collection of this site allowed A.V. Buyskikh to attribute its functioning to the first third of the VI century BC, and to suppose that it functioned, in fact, within the life of one generation of colonists. According to researchers, the site is in use from the first quarter of the VI century BC, but it does not survive even until the middle of the century (Buyskikh and Buyskikh 2010, 24-26).

There are two more funerary complexes of the Dnieper Forest-Steppe that we know of, which, based on finds of ancient Greek vessels together with the beads under question, confirm the dating of the production and usage of these adornments in the chronological framework of the Yahorlyk settlement.

The first such complex is the standard one for the chronology of Early Scythian material culture – the inlet burial of the Repiakhuvata Mohyla in the Dnieper right-bank Forest-Steppe (Ilinskaya *et al.* 1980). The find of the Miletus amphora and the Ionian jug in the complex, together with the beads, enable us to attribute this complex to the first two decades of the VI century BC (Fig. 3; see discussion: Grechko 2012).

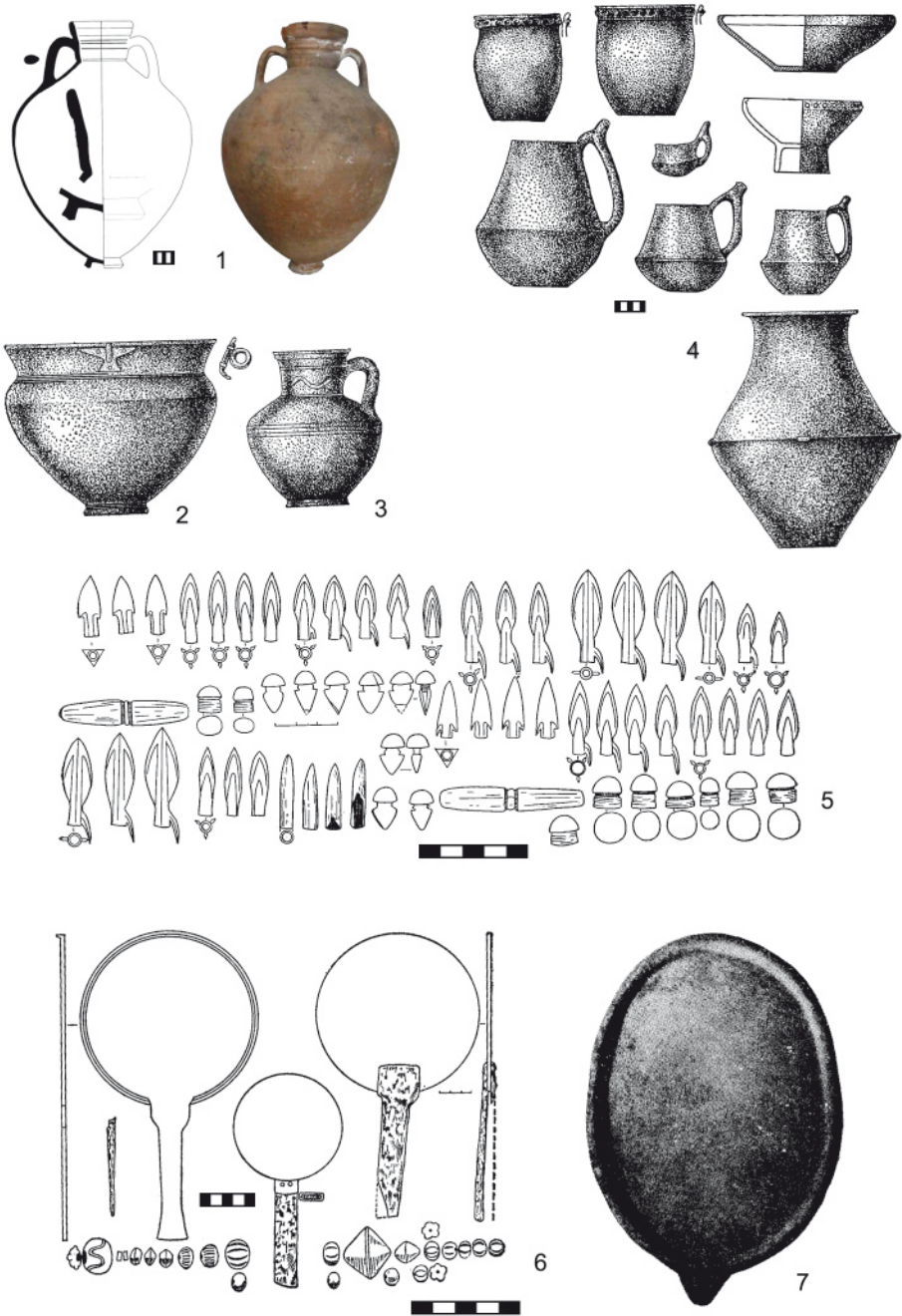

Fig. 3. Inventory of the inlet burial of Repiakhuvata Mohyla (Ilinskaya et al. 1980; Daragan 2010)

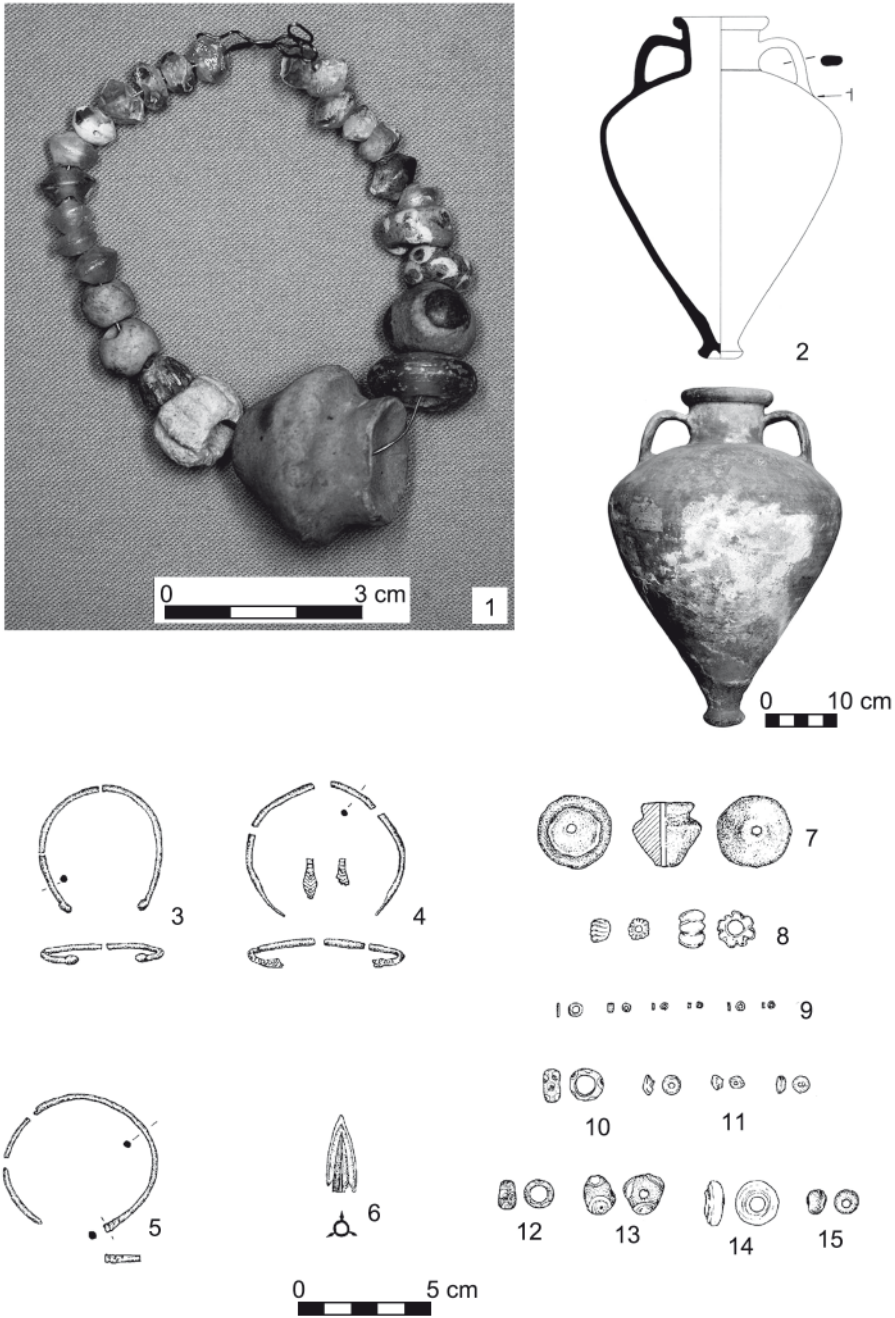

Fig. 4. Finds from mound No. 5 near Vovkivtsi village in the Sula River region (Lomtadze and Firsov 2012)

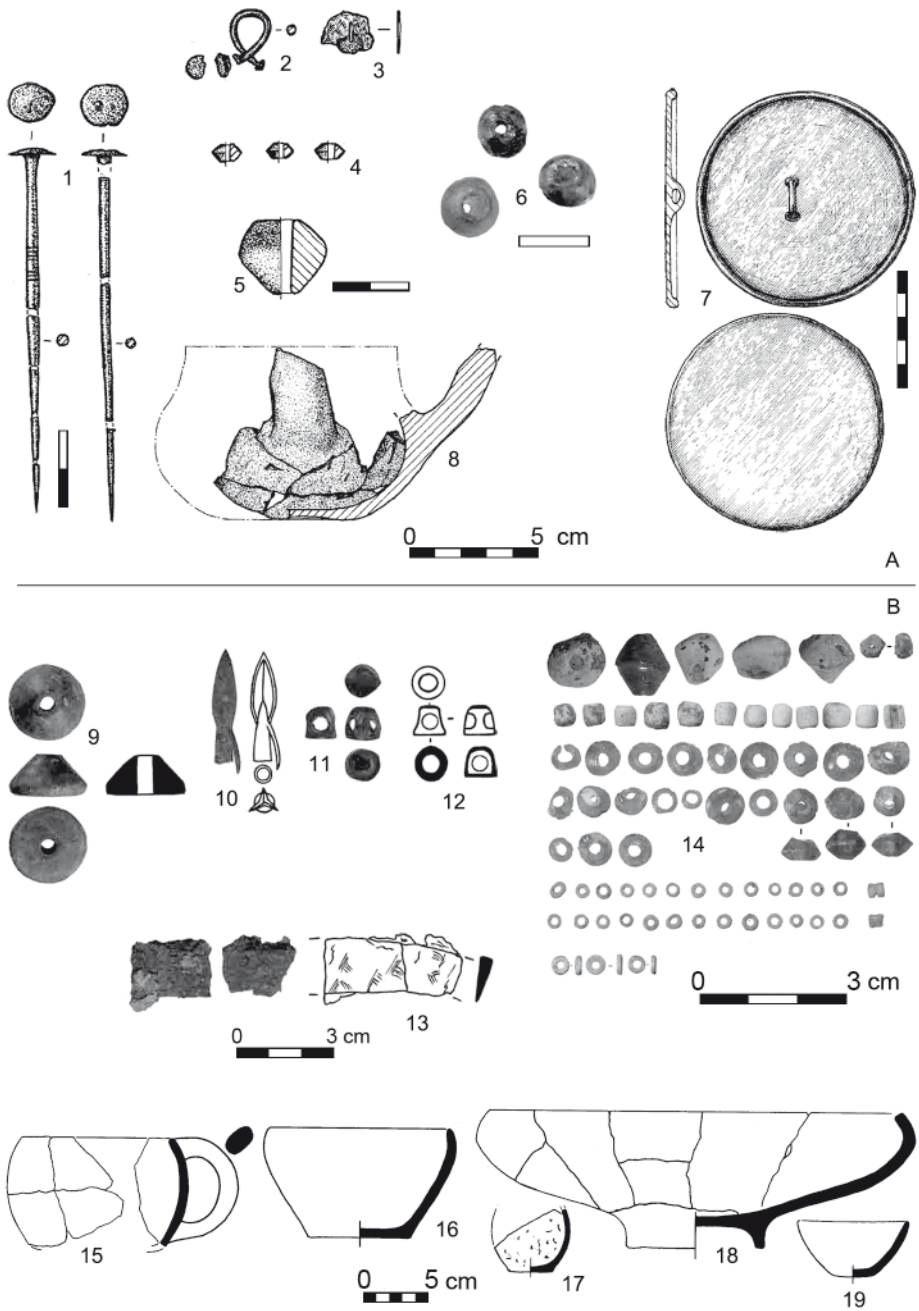

Fig. 5. Inventory of burial No. 1 in Poltava (1) and the burial in barrow No. 1/2016 in Skorobir (Bilsk) site (Suprunenko 2016; Shramko 2017)

In the burial mound near Vovkivtsi village in the Sula River basin (Dnieper left-bank forest-steppe; Fig. 1: 2), along with a set of adornments (biconical beads, bracelets, *etc.*), the archaic Samos amphora of the first quarter (third?) of the VI century BC was revealed (Fig. 4; Lomtadze and Firsov 2012, 281-297). In addition, similar beads were found in the Sula River basin in mound No. 2 near Vovkivtsi village, and in mound No. 2 in the Solodka locality (Ilinskaya 1968, Pl. 12: 27-28, 34: 11).

This dating does not contradict the complex of barrow No. 1/2016, investigated in the Skorobir locality in Bilsk, which was also dated by Iryna Shramko to the first quarter of the VI century BC (Fig. 5: B; Shramko 2017, 378).

One of the most archaic complexes with biconical glass beads could be burial No. 1 in Poltava, on the right bank of the Vorskla River (Fig. 5: A), which was accompanied by a bronze mirror with a central handle, pins and nail-shaped earrings (Fig. 9: A; Suprunenko 2016, 264, fig. 6). On the other hand, the discovery of the beads, which were made at the Yahorlyk settlement, suggests the usage of similar mirrors in the first quarter of the VI century BC, as researchers have already noted (Shramko 2017, 375). In general, mirrors are often older than the age of the burial, which may indicate their continued usage. As an example, one could mention Aksai-I, burial mound No. 10/1. Mirrors with a broken central handle, as well as so-called "Olbian-type" were found in the burial. Researchers justifiably consider the mirrors to be older than the burial itself (V c. BC; Shilov and Ochir-Goriaeva 1997, 132, 151). It is worth adding, in my opinion, that the mirrors themselves are clearly asynchronous.

Another vector of synchronization is provided by the complex of barrow No. 5 near Spasivka village on the Middle Dniester River (Mogilov 2016). In the burial, among the inventory biconical beads, a bronze arrowhead of the transitional period – analogies: Debastopolchany (Szabó *et al.* 2014), Smolenice-Molpir (Hellmuth 2006) – and a horn cylinder with geometric ornaments (Fig. 6: 5; Mogilov *et al.* 2016, 220, fig. 13) were found. The closest analogy to this cylinder is an item from mound No. VI of the Trinka necropolis (Trinka-Drumul Fetestilor), where similar biconical beads were discovered (Fig. 6: 3). This burial ground was left by a mixed population, which was influenced by the Western Podolian and Podolian-Moldavian cultural groups. Researchers date the necropolis from the middle of the VII – the first quarter of the VI century BC (Levitsky and Kashuba 2009, 257-263). Findings of beads help to clarify the dating of these complexes, placing them specifically in the first quarter (third?) of the VI century BC.

The complexes with biconical beads from burials of the TLC (Fig. 7: 1-2) were attributed by specialists to the period III/1 (HaD) – the beginning of LtA (second half of the VI – the first half of the V c. BC; Czopek *et al.* 2016, 88). Burials were accompanied by nail-shaped earrings, pins with loop-shaped heads and earrings of the "Kłyżów type" (Modnica, 5, feature 927; Dziegielewski 2015, 91, fig. 62, b, c, d). It should be noted that unlike pins, fibulae were not actually used by the TLC tribes (Gedl 2004).

An interesting parallel is mound complex No. 3 near Teklivka village on the Middle Dniester River, where both types of earrings were found together (Fig. 7: 4; Gutsal *et al.* 2011).

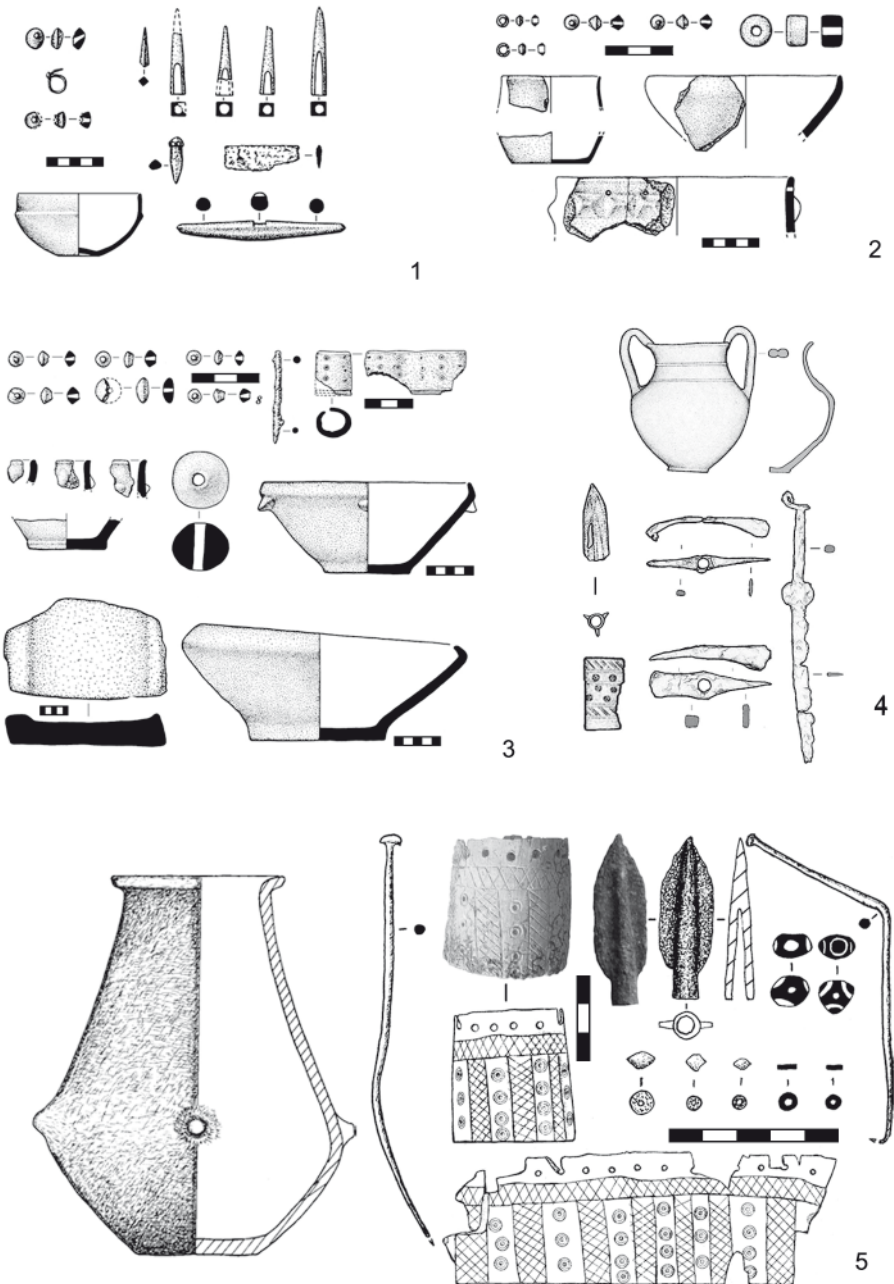

Fig. 6. Materials from the burials of the Late Hallstatt period of the Dniester River region and the Danube basin. 1 – Trynka, barrow No. I; 2 – Trynka, barrow No. II; 3 – Trynka, barrow No. VI; 4 – Bâtmonostor-Szurdok; 5 – Spasivka, barrow No. 8 (Levitsky and Kashuba 2009; Mogilov 2016; Gyucha *et al.* 2015)

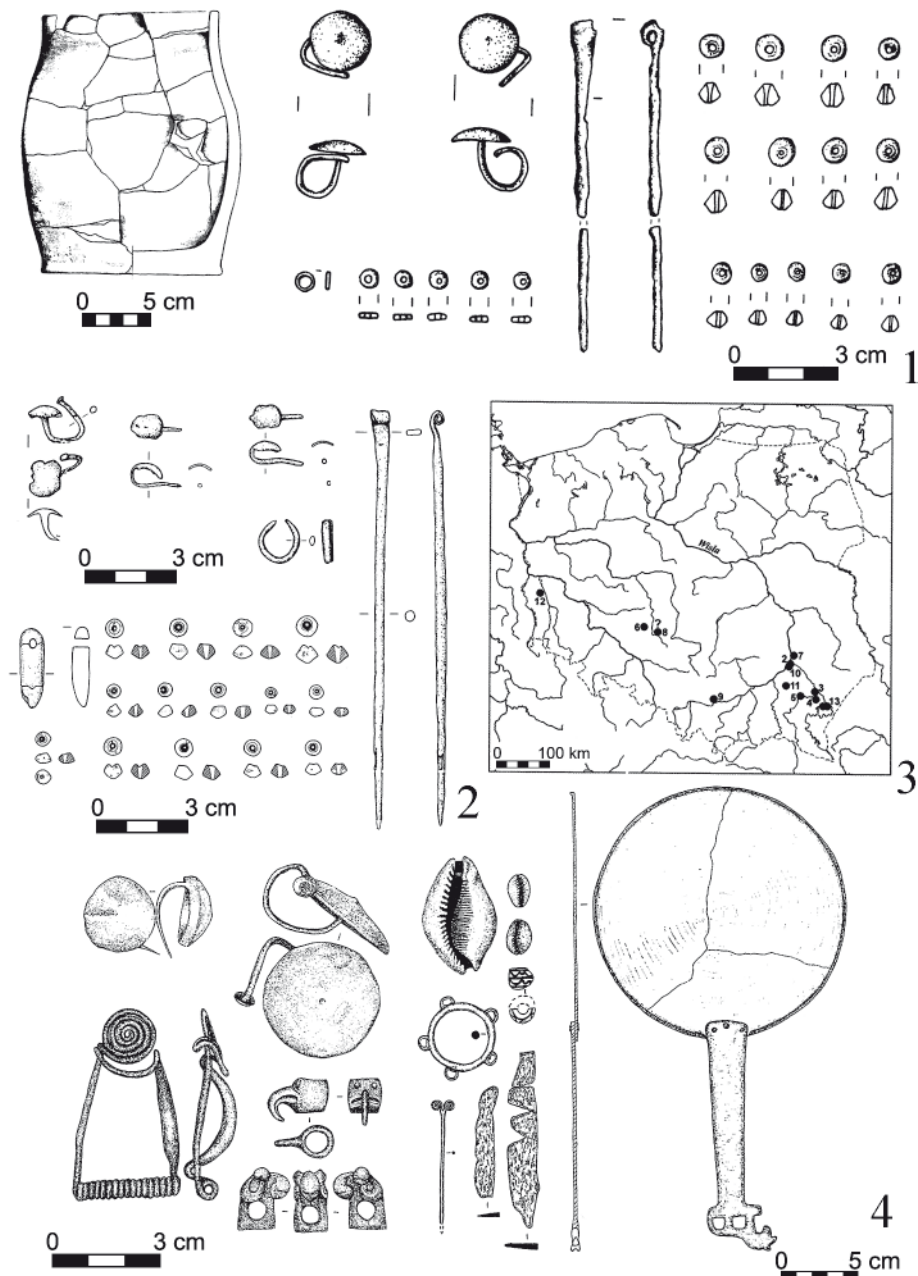

Fig. 7. Complexes of the Lusatian culture with biconical glass beads, and the materials from burial mound No. 3 near Teklivka in the Dniester River basin (4; Gutsal *et al.* 2011). 1 – Grzęska, burial No. 54 (Czopek *et al.* 2016); 2 – Modlnica, site No. 5, burial No. 927 (Dzięgielewski 2015); 3 – biconical beads in the Vistula-Oder interfluvium (Purowski 2015)

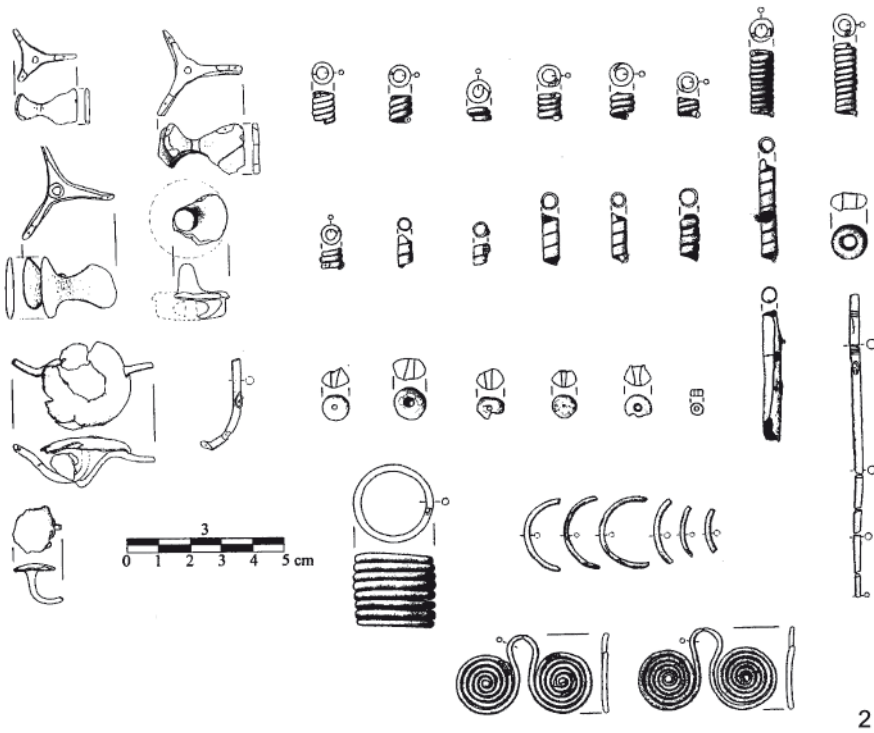
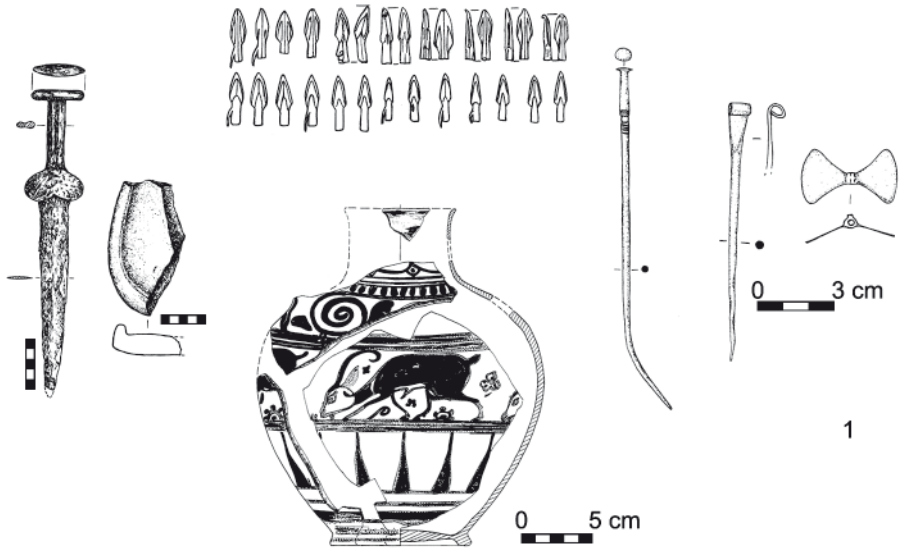

Fig. 8. Materials from the destruction layers of the Trakhtemyriv hillfort (1; Fialko and Boltryk 2003) and the complex of finds from Zablotce (2; Bajda-Wesołowska et al. 2014)

J. Kowalski-Bilokryly considers them (“Kłyżów type”) to be imitations of gold items of the late VII – the early VI century BC, represented in the Western Podolian group (Teklivka, mound No. 3; Dolyniany; Kowalski-Bilokryly 2014, 63). S. Czopek also suggests the eastern origin of these items (Czopek 1996). An important find *vis-à-vis* dating is a bronze, harp-shaped fibula (Gutsal *et al.* 2011), found in the Teklivka complex. Similar fasteners are typical for the Eastern Hallstatt and are well-known at the complexes of periods HaC-D of the Lusatian culture (Gedl 2004, 87-88).

In the Zabłotce complex, along with biconical beads, nail-shaped earrings and three triple-bladed products similar to propellers were found (Fig. 8: 2; Bajda-Wesołowska *et al.* 2014). It is worth mentioning an important find of a similar product in the moat of the Trakhtemyriv hill-fort, along with arrowheads and a Wild-Goat-style “B” oenochoe (Northern Ionia, Klazomenai?; Fig. 8: 1), which experts dated back to the second decade of the VI century BC (Fialko and Boltryk 2003, 42, 59-61). This analogy does not contradict the dating of this layer (horizon) of monument, in which biconical glass beads were found, to the first quarter (third?) of the VI century BC.

One of the benchmarks can be the date of the destruction of the Wicina fortified settlement, which is the westernmost location in which biconical glass beads have been found (Purowski 2015, 226, fig. 5). According to dendrochronology, it is now determined to be sometime after 571 BC (the time of the last repair of wooden defensive structures – Krapiec and Szychowska-Krapiec 2013, 373-374). Recently, Jan Chochorowski, based on the totality of the data, placed the destruction of the fortification no later than 560 BC (570/560 BC; Khokhorovsky 2019, 229). This dating of the final functioning of the settlement does not contradict the fact that biconical glass beads were used in the first third of the VI century BC.

These ancient Greek items could have penetrated so far west via the traditional path along the Dniester River and the northern slopes of the Carpathians. Interestingly, this route could have been used by nomads during a campaign in Central Europe around the middle of the VI century BC (Fialko and Boltryk 2003, 88, fig. 32). Two daggers from Silesia could be related to the nomad campaign (Legnica and Łubnice; Bukowski 1977; Baron and Miazga 2013).

VARIANT OF CHRONOLOGICAL SCHEMES SYNCHRONIZATION

The horizon of “biconical glass beads” / HaD1 / The second phase of the Kelermes period / III/1 (time of peaceful co-existence and exchange). To synchronize the chronological horizons of different groups of the Lusatian population, fibulae are of great importance. For example, harp-shaped fibulae are typical for the Kietrz V period (from HaC – the beginning of HaD; Gedl 1979, fig. 5). Similar fibulae are found in mound No. 3 near Teklivka village on the Middle Dniester River (Fig. 7: 4; Gutsal *et al.* 2011), which belongs to





BC	Subwest Rheinische u. a. Hansen L. 2016	Tamobrzeg Lusatian culture (Czopek 2018)	Eastern Europe (Grechko 2013, 2016)	Lusatian culture	Eastern materials in the Central Europe
620	HaD1	III 1 phase	Kelermes period, phase 2		
600					
550	HaD2		Transitional period		
500					
	Middle Scythian period, phase 1				
				III 2 phase (Lt A-B/HaE)	Middle Scythian period, phase 2

Fig. 9. The variant of the chronological schemes synchronization of Central and Eastern Europe. 1 – Grzęska, burial No. 54; 2 – Chotyńiec; 3 – Grodzisko Dolne, site No. 22; 4-5 – Wicina; 6 – Trójczyce (burial No. 102); 7 – Ulanov-Zwolaki; 8 – Łągownik (burial No. 7/59); 9 – Obojna-Zaosie (burial No. 10); 10 – Kłodnica; 11 – Kosin (burial No. 8/1925); 12 – Byčí Skála Cave (Bukowski 1977; Czopek 2007; Czopek *et al.* 2016; Czopek 2019; Gedl 2004; 2014)

the second Kelermes period (the last two decades of the VII – the first quarter (third?) of the VI c. BC; Grechko 2013). A mirror with a side handle indicates that this complex cannot be dated earlier than the end of the VII – the beginning of the VI century BC; however, it allows for the possibility of its synchronism with the inlet burial of the Repiakhuvata Mohyla. It allows us to speak confidently about the usage of harp-shaped fibulae at the beginning of the VI century BC (6th period, according to H. Parzinger). This complex, due to the nail-shaped earrings and an earring of the “Kłyżów type” (Teklivka, mound No. 3 – Fig. 7: 4), can be synchronized with the early part of phase III/1 for the TLC and the complexes of the Transylvanian group of monuments. Complexes with the biconical glass beads belong to this horizon, which can be synchronized with the HaD1 period (Fig. 9: 1). The Chotyńiec agglomeration of monuments, which was founded by the immigrants from the Eastern European Forest-Steppe, existed and actively operated in the contact zone with the TLC at that time (Fig. 9: 2; Czopek 2019). One of its functions could have been to establish contacts and facilitate exchange with the tribes of the Lusatian culture.

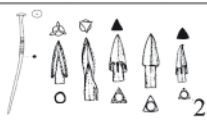
Horizon of destabilization in Central and Eastern Europe – “Scythian invasions” and Vekerzug influences (raids?). The early group can be synchronized with the destruction of ancient cities in Central Europe, and is characterized by arrowheads of the types that were

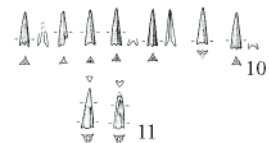
found at Smolenice-Molpir (Hellmuth 2006). At the Wicina fortified settlement, which was destroyed around 570/560 BC, several crossbow-shaped fibulae (Fig. 9: 4-5) were found that were previously attributed to the HaD3 period (Gedl 2004). Despite a significant number of finds of crossbow fibulae (variant Wicina after M. Gedl) in the burials of the Lusatian and Pomeranian cultures (Gedl 2004), the lack of reliable chronological indicators makes them difficult to date. For example, radiocarbon dating of the burial 1801 Kietrz burial ground did not meet expectations (274±90 BC; Chochorowski 2007, 127).

New dating of the Wicina destruction allows us to date the earliest use of this type of fastener to the end of the HaD1 period. This can be established thanks to the updated dates of the West Hallstatt periodization (Egg and Kramer 2016) and the critically reviewed chronology and periodization of M. Trachsel (HaD2: 595-565 BC; HaD3: 570-530 BC; Trachsel 2004, 318), which was completed by Hansen and Leif (2008, 233-234). Also, these fibulae are already typical for the Kietrz VIa (HaD) horizon, according to M. Gedl (Gedl 1979, fig. 5).

The late group of complexes of this horizon is associated with the completion of campaigns and the formation of the Vekerzug culture, with its characteristic armaments and bridles. Some of the fortifications in Central Europe, mainly in Moravia, which is adjacent to the main area of the Vekerzug culture, bear traces of the military activity of this culture (Krzepice, Jaroměřice).

Complexes of the TLC of this time can be distinguished by the presence of arrowheads in the burials typical for the Vekerzug culture (Gedl 2014, 57-58). This pertains to the following burials: Obojna-Zaosie (burial No. 10 – Fig. 9: 9), Trójczyce (burial No. 102; Fig. 9: 6), Ulanów -Zwolaki (Fig. 9: 7), and Łagiewniki (burial No. 7/59; Fig. 9: 8). These burials can be synchronized with the Vitova Mohyla horizon and the first phase of the Middle Scythian Period, according to D.S. Grechko (Grechko 2016a; 2016b). Whereas the arrowheads of the transitional period, from the destruction layers of Wicina and other fortifications, belong to the initial phase of this horizon.

A fragment of an arrowhead from the settlement of Ninovychi should also be mentioned. It can be dated from the end of the VI – the first half of the V century BC (Czopek *et al.* 2018, 289, fig. 9.35.2). However, it cannot be ruled out that it belongs to the type with the outer socket of the previous horizon. Fragments of handmade pots can be more confidently correlated with Chotyniec materials than with Grodzisko Dolne, site No. 22.

In general, it is worth noting the small number of monuments, compared with the previous horizon, and the poverty of materials in this horizon in the TLC area (late group of phase III/1). Almost all arrowheads were found in burials of the Lusatian culture, which may indicate other reasons for their appearance in this region than in Moravia (in settlements and hillforts with traces of military operations).

This horizon includes materials from the TLC at Grodzisko Dolne, site 22 (Czopek 2007). The shape of the nail-shaped earrings changes, and their flap acquires a triangular sectional shape (Fig. 9: 3). Similar changes in these adornments are also recorded for

products of the transitional period of the south of Eastern Europe (the second – the beginning of the third quarter of the VI c. BC). The ceramic complex of this monument differs from the Chotyniec agglomeration (Chotyniec, Hrushovychi settlement): there is practically no applied strips in vessels ornamentation, cauldron-shaped pots dominate, almost all the pots have a rusty outer surface (about 56% (Czopek 2007, 183, tab. 9), and bowls with pin holes and applied strips are rare, like this type of cooking ware in general (Czopek 2007, Tabl. 14, 15, 20, 38: 2). Differences in the ceramic complexes, of course, are not only chronological, but also ethnic in nature, since Grodzisko Dolne, site No. 22, belongs to the TLC, unlike Chotyniec. Although, in burial Nos. 37 and 51 of the TLC necropolis at Grzęska, the pots typical for the Chotyniec agglomeration were found (Czopek *et al.* 2016, 36, fig. 2.23, 4, 6; 44, fig. 2.32, 3). Summing up, according to the dating of amphorae, arrowheads and pins (Fig. 9: 2; Czopek 2019, 127-130), the population of the Chotyniec agglomeration left no later than the end of the first third of the VI century BC.

Thus, the horizon following the destruction of sites in the Eastern Hallstatt region (Smolenice-Molpir, *etc.*) and sites of the Lusatian culture (Wicina) is rightfully synchronized with the end of the periods HaD1-HaD2 (the so-called “Scythian invasions” horizon), and can be dated between 570/560-520/510 BC (transitional period and the horizon of the Vitova Mohyla, according to D. Grechko 2016a). Glass biconical beads and nail-shaped earrings with lenticular shields are no longer present in this period. This horizon marked the minimization of contacts of the remaining population of the TLC with the more eastern regions of the Forest-Steppe, and the movement of the main vector of ethno-cultural interaction to the north, towards the tribes of the Pomeranian culture.

A crisis in the environment of the Lusatian culture tribes and the actual population decline at this time can be assumed – particularly in the area of the TLC. In general, the weakening of the demographic potential and the decline in the material culture of the Late Lusatian tribes should be noted, which could have been caused by invasions of nomads from the east around the middle of the VI century BC, among other factors (Dzięgielewski 2016, 20). One of the reasons for the “Pomeranian expansion” could be the cessation of the active usage of the Amber Road as a result of the “Scythian invasions” and the formation of the Vekezug culture, since all of this interrupted the exchange of metal with the Lusatian tribes of Silesia (Dzięgielewski 2016, 30).

In this regard, the appearance of early complexes of the Pomeranian culture in the region, such as Zastavne (Pavliv *et al.* 2010), which can be attributed to Karczemki (IIB₁) = HaD) phase (Dzięgielewski 2017, 300), is worth mentioning. Karol Dzięgielewski believes that the penetration of the Pomeranian population into the Vistula River basin had its own particularities. It was small groups (individual cyst burials) that initially spread into this region – groups that were eventually assimilated (Dzięgielewski 2016, 32). Using a comprehensive approach and taking all of the above into account, we can say that the Pomeranian population had already begun to penetrate into the south-eastern area of the Lusatian

tribes by the second half of the VI century BC, and the formation of a new cultural model was underway (post Lusatian-Pomeranian stage: Dziegielewski 2016, 32).

The horizon of sporadic contacts with the Scythians of the Northern Black Sea region. Well-dated materials of eastern origin, e.g., arrowheads and horse bridle parts, such as the Chilik-Dere type from Býčí skála Cave (Fig. 9: 12; Simion 2000; Bukowski 1977), from the end of the VI – the first half of the V century BC (HaD3, the final part of phase III/1 TLC) are rare in the TLC area, and are mainly represented by random finds (Hrebenne, Kłodnica – Fig. 9: 10, Kosin, burial No. 8/1925 – Fig. 9: 11; Gedl 2014, 57). This horizon is characterized by the completion of the formation of Scythia in the Northern Black Sea region, which for two centuries will be a kind of shield for Central Europe against invasions from the East. Increasingly from this time, the history of the tribes of the southern part of Eastern Europe will be associated with the dominance of different groups of Iranian-speaking nomads (Scythians and Sarmatians), while Western and Central Europe will be under the increasing influence of the Celts.

CONCLUDING REMARKS

1. Biconical glass beads, which were produced at the Yahorlyk settlement in the Northern Black Sea region in the first third of the VI century BC, mark the chronological horizon of the complexes synchronous to the HaD1 period of Central Europe, phase III/1 of the TLC and the late group of burials of the second phase of the Kelermes period.

2. The final stage of this horizon is associated with the destabilization of the military-political situation in the region (the so-called “Scythian invasions”). The activity of nomads, in combination with other factors, could have led to the abandonment of the sites of the Chotyniec agglomeration, as well as those of the Western Podolian and Eastern Podolian groups. Significant changes in the system of the tribes’ settlement of Central and Eastern Europe, along with changes in material culture, confirm the opinion of researchers that the time around the middle of VI century BC was the boundary between the HaD1 and HaD2 periods. The role of nomadic invasions from the East in the transformation of the ethnic and cultural map of Central Europe was probably more significant than previously thought.

3. A few TLC complexes of the Grodzisko Dolne, site 22 type can be dated between the middle and the second half of the VI century BC (HaD2). This time marked the beginning of the penetration of Pomeranian populations into the south-eastern area of the Lusatian tribes, and the formation of a new culture model (post Lusatian-Pomeranian stage, after Karol Dziegielewski).

4. The presented work only outlined several possibilities for highlighting individual periods in the phase III/1 of the TLC, which is a task for future fundamental research of Polish and Ukrainian specialists.

References

- Bajda-Wesołowska A., Bochnak T. and Hozer M. 2014. Bogaty grób kobiety z wczesnej epoki żelaza odkryty w miejscowości Zablótce, pow. Jarosławski, stan. 27. *Materiały i Sprawozdania Rzeszowskiego Ośrodka Archeologicznego* 35, 105-125.
- Baron J. and Miazga B. 2013. Scythian akinakes or medieval kidney-dagger? Archaeometric study of a recent find from Legnica (South-Western Poland). *Archäologisches Korrespondenzblatt* 43(3), 335-343.
- Boltryk Yu. V., Horbanenko S. A., Kubliy M. V., Serheyeva M. S. and Yanish Ye. Yu. 2015. Severynivske horodysche skifskoho chasu: biohospodarsky aspekt doslidzhen. *Arkheolohiya i davnia istoria Ukrayiny* 4(17), 155-192.
- Bukowski Z. 1977. *The Scythian influence in the area of Lusatian culture*. Wrocław, Warszawa, Kraków, Gdańsk: Zakład Narodowy im. Ossolińskich.
- Buyskikh S. B. and Buyskikh A. V. 2010. K khronologii arkhaiskikh poseleniy khory Olvii Pontyskoy. *Bosporskiye issledovaniya* 24, 3-64.
- Chochorowski J. 2007. Metodyczne i metodologiczne problemy datowania radiowęglowego pozostałości kremacji z grobów ciepłopalnych kultury łużyckiej (na przykładzie materiałów z cmentarzyska w Kietrze). In J. Chochorowski (ed.), *Studia nad epoką brązu i wczesną epoką żelaza. Księga poświęcona Profesorowi Markowi Gedłowi na pięćdziesięciolecie pracy w Uniwersytecie Jagiellońskim*. Kraków: Uniwersytet Jagielloński, 103-138.
- Czopek S. 1996. Kolczyki typu Kłyżów. Przyczynek do poznania schyłkowej fazy grupy tarnobrzeskiej. In J. Chochorowski (ed.), *Problemy epoki brązu i wczesnej epoki żelaza w Europie Środkowej. Księga jubileuszowa poświęcona Markowi Gedłowi w sześćdziesiątą rocznicę urodzin i czterdziestelecie pracy w Uniwersytecie Jagiellońskim*. Kraków: Uniwersytet Jagielloński, 163-173.
- Czopek S. 2007. *Grodzisko Dolne, stan. 22 – od paleolitycznych łowców do wczesnośredniowiecznych Słowian. Część I. Od epoki kamienia do wczesnej epoki żelaza*. Rzeszów: Uniwersytet Rzeszowski.
- Czopek S. 2011. Zwischen der Chronologie und Funktion. Horizont(?) der Gräber mit Glasperlen auf den Gräberfeldern der späten Phase der Tarnobrzeg – Lausitzer Kultur. *Sprawozdania Archeologiczne* 63, 115-134.
- Czopek S. 2019. Enklawa scytyjskiego kręgu kulturowego w południowo-wschodniej Polsce. *Przegląd Archeologiczny* 67, 119-148.
- Czopek S., Ligoda J., Podgórska-Czopek J. and Rogóż J. 2016. *Cmentarzysko tarnobrzeskiej kultury łużyckiej z wczesnej epoki żelaza w Grzęsce, pow. Przeworski*. Rzeszów: Instytut Archeologii UR.
- Chopek S., Trybala-Zavislyak K., Voytseshchuk N., Osaulchuk O., Bobak D., Hembitsa P., Yatsyshyn A., Pasterkevich V., Pavliv D., Petehyrych V., Poltovich-Bobak M. and Vatsnik A. 2018. *Kulturno-poselenski zminy v baseyni richky Vyshnya v epokhu bronzy i za doby rannoho zaliza v konteksti zmin doistorychnoyi i rannoserednivichnoyi oykumeny*. Rzeszów: Instytut Archeologii UR.

- Daragan M. N. 2010. O datirovke amfory iz pogrebeniya № 2 Repyakhovoy Mogily. *Antichnyi mir i arkeologiya* 14, 175-202.
- Dzięgielewski K. 2015. Zespół osadniczy z późnej epoki brązu i wczesnej epoki żelaza w Modlnicy. In K. Dzięgielewski, M. Dzięgielewska and A. Szyber (eds), *Modlnica, stan. 5. Od późnej epoki brązu po czasy średniowiecza (Via Archaeologica. Źródła z badań wykopaliskowych na trasie autostrady A4 w Małopolsce)*. Kraków: Krakowski Zespół do Badań Autostrad, Wydawnictwo Profil-Archeo, 9-196.
- Dzięgielewski K. 2016. Societies of the younger segment of the early Iron Age in Poland (500-250 BC). In P. Urbańczyk (ed.), *The Past Societies. Polish lands from the first evidence of human presence to the early Middle Ages*. Volume 4: 500 BC – 500 AD. Warszawa: Instytut Archeologii i Etnologii PAN.
- Dzięgielewski K. 2017. Late Bronze and Early Iron Age communities in the northern part of the Polish Lowland (1000-500 BC). In P. Urbańczyk (ed.), *The Past Societies. Polish lands from the first evidence of human presence to the early Middle Ages*. Volume 3: 2000-500 BC. Warszawa: Instytut Archeologii i Etnologii PAN.
- Fialko O. Ye. and Boltryk Yu. V. 2003. *Napad skifu na Trakhtemirivske gorodysche*. Kyiv: Korvin Press.
- Gedl M. 1979. Stufengliederung und Chronologie des Gräberfeldes der Lausitzer Kultur in Kietrz (= *Prace Archeologiczne* 27). Kraków: Państwowe Wydawnictwo Naukowe.
- Gedl M. 2004. Die Fibeln in Polen (= *Prähistorische Bronzefunde* 14/10). Stuttgart: Franz Steiner Verlag.
- Gedl M. 2014. Die Pfeilspitzen in Polen. (= *Prähistorische Bronzefunde* 5/6). Stuttgart: Franz Steiner Verlag.
- Grechko D. S. 2012. O vozmozhnykh «prosvetakh» v «temnoye» vremya (VI v. do n. e.) skifskoy istorii. *Stratum plus* 3/2012, 75-106.
- Grechko D. S. 2013. O pamyatnikakh kimmeriytsev i “ranneskifskoy” kul'ture. *Stratum plus* 3, 133-154.
- Grechko D. S. 2016a. Ot Arkhaischeskoy Skifii k Klassicheskoy. *Arkeologiya i davnia istoriya Ukrainy* 2(19), 33-60.
- Grechko D. S. 2016b. Klassicheskaya Skifiya: nachalo (posledniye desyatiletiya VI – pervaya chetvert V v. do n. e.). *Revista arheologica* 12(1-2), 145-168.
- Gutsal A. F., Gutsal V. A. and Mogilov A. D. 2011. Kurgan №3 u s. Teklivka na Srednem Dnestre. In V. D. Berezhitskiy (ed.), *Vostochnoevropeyskie drevnosti skifskoy epokhi: sbornik nauchnykh trudov*. Voronezh: Nauchnaya kniga, 97-109.
- Hansen L. 2008. *Die Goldfunde und Trachtbeigaben des späthallstattzeitlichen Fürstengrabes von Eberdingen-Hochdorf (Kr. Ludwigsburg)*. Dissertation, Christian-Albrechts Universität zu Kiel.
- Hellmuth A. 2006. *Untersuchungen zu den sogenannten skythischen Pfeilspitzen aus der befestigten Höhensiedlung von Smolenice-Molpír* (= *Universitätsforschungen zur prähistorischen Archäologie* 128). Bonn: Rudolf Habelt GmbH.
- Ilinkaya V. A. 1968. *Skify Dneprovskogo Lesostepnogo Levoberezhia (kurgany Posulya)*. Kyiv: Naukova dumka.

- Ilinskaya V. A., Mozolevskiy B. N. and Terenozhkin A. I. 1980. Kurgany VI v. do n. e. u s. Matusov. In A. I. Terenozhkin (ed.), *Skifiya i Kavkaz*. Kyiv: Naukova dumka, 31-64.
- Khokhorovsky Y. A. 2019. Na dalekykh ukrainakh antichnogo mira: giperboreytsy Tsentralnoy Evropy. *Arkheolohiya i davnia istoriya Ukrayiny* 2(31), 197-254.
- Kowalski-Bilokrylyy J. 2014. Pochodzenie kolczyków typu Kłyżów. *Materiały i Sprawozdania Rzeszowskiego Ośrodka Archeologicznego* 35, 59-64.
- Krapiec M. and Szychowska-Krapiec E. 2013. Analiza dendrochronologiczna drewna z badań grodziska w Wicinie w latach 2008-2012. In: A. Jaszewska and S. Kałagate (eds), *Wicina. Badania archeologiczne w latach 2008-2012 oraz skarb przedmiotów pochodzących z Wiciny*. Zielona Góra: Fundacja Archeologiczna, 371-417.
- Levitskiy O. G. and Kashuba M. T. 2009 O kulturnykh traditsiyakh v pogrebalnoy obryadnosti naseleeniya, prozhivayushchego na zapadnykh rubezhakh arkhaiskoy Skifii (istochniki, problematika). *Arkheolohiya i davnia istoriya Ukrayiny*, 250-267.
- Lomtadze G. A. and Firsov K. B. 2012. Kompleks ranneskifskogo vremeni iz kurgana u sela Volkovtsy v Posulye (po materialam iz sobraniya GIM). In: D.V. Zhuravlev and K.B. Firsov (eds.), *Euraziya v skifo-sarmatskoye vremia. Pamyati Iriny Ivanovny Guschinoy*. Moskva: GIM, 281-298.
- Mogilov O. D., Gutsal A. F. and Gutsal V. A. 2016. Kurgan z kamyanim valom na Zakhidnomu Podilli. *Arkheologiya i davnia istoriya Ukraini* 2(19), 212-230.
- Ostroverkhov A. S. 1978. Antychna sklorobna maysternia na Yagorlytskomu poseleenni. *Arkheolohiya* 25, 41-49.
- Ostroverkhov A. S. 1981. Obrobka kolorovykh metaliv na antychnykh poseleenniakh. *Arkheolohiya* 36, 26-37.
- Pavliv D., Mylian T. and Osaulchuk O. 2010. Unikalne pokhovannia pomorskoyi kultury poblyzu s. Zastavne na Lvivschyni. *Materiały i doslidzhennia z arkheolohiyi Prykarpattia i Volyni* 14, 258-272.
- Purowski T. 2012. *Wyroby szklane w kulturze lużyckiej w międzyrzeczu Noteci i środkowej Odry. Studium archeologiczno-technologiczne*. Warszawa: Instytut Archeologii i Etnologii PAN.
- Purowski T. 2015, Paciorki szklane z cmentarzyska z wczesnej epoki żelaza w Modlnicy. In K. Dzięgielewski, M. Dzięgielewska and A. Szyber (eds), *Modlnica, stan. 5 Od późnej epoki brązu po czasy średniowiecza (= Via Archaeologica. Źródła z badań wykopaliskowych na trasie autostrady A4 w Małopolsce)*. Kraków: Krakowski Zespół do Badań Autostrad, Wydawnictwo Profil-Archeo, 219-238.
- Samek L., Karwowski M., Czopek S., Ostachowicz J. and Stegowski Z. 2007. Analysis of Glass Beads from the Graves of the Tarnobrzeg Lusatian Culture in Jasionka and Grodzisko Dolne Employing the X-ray Fluorescence Method. *Analecta Archaeologica Ressoviensia* 2, 101-118.
- Shramko I. B. 2017. Novyi pohrebalnyi kompleks ranneskifskogo vremeni v mogilniku Skorobor. *Arkheolohiya i davnia istoriya Ukrayiny* 2(23), 368-380.
- Shylov V. P. and Ochir-Goriaeva M. A. 1997. Kurgany skifskoy epokhi iz mogilnikov Aksenovskiyi-I-II. *Materiały i issledovaniya po arkheologii Rossii* 1, 127-152.

- Simion G. 2000. Tombes tumulaires de la nécropole de Celic-Déré. Tombes tumulaires de l'Âge du Fer dans le Sud-Est de l'Europe. In G. Simon, V. Lungu (eds), *Actes du II Colloque International d'Archéologie Funéraire*. Tulcea: Institut de Recherches Eco-Museologiques de Tulcea, 69-82.
- Suprunenko O. B. 2016. Hruntovi nekropoli lisostepovoho naseleattia skifskoyi doby u Dniprovskomu Livoberezhzi. *Arkheolohiya i davnia istoriya Ukrainy* 2(19), 257-269.
- Szabó G. V., Czajlik Z. and Reményi L. 2014. Traces of an Iron Age armed conflict. New topographical results from the research into Verebce-bérc at Dédestapolcsány I. *Hungarian archaeology E-journal* 2014 (Winter), 1-7.
- Trachsel M. 2004. Untersuchungen zur relative und absoluten Chronologie der Hallstattzeit (= *Universitätsforschungen zur prähistorischen Archäologie* 104). Bonn: Dr. Rudolf Habelt.

