

Sabina Stempniak-Kusy<sup>1</sup>, Anna Lasota-Kuś<sup>2</sup>

## BURIAL OF A MOUNTED WARRIOR WITH *RINGKNAUFSCHWERT*-TYPE SWORD FROM THE NECROPOLIS IN OSTRÓW, PRZEMYŚL DISTRICT

### ABSTRACT

Stempniak-Kusy S. and Lasota-Kuś A. 2021. Burial of a mounted warrior with *Ringknaufschwert*-type sword from the necropolis in Ostrów, Przemyśl District. *Sprawozdania Archeologiczne* 73/2, 221-249.

During the excavation of the Przeworsk culture necropolis at Site 21 in Ostrów, Przemyśl District, a richly furnished burial of a mounted warrior was found. The burial, which can be dated to the developed stage of the Early Roman period based on the grave goods, stood out through the lavishness of its grave inventory. Among other objects, the grave goods included a sword with a ring-like pommel, known as a *Ringknaufschwert*, two spearhead, one of them with punched decoration, and elements of horse tack. There also were ornaments and dress items, particularly noteworthy among them a gold pelta-shaped pendant decorated with granulation.

Keywords: *Ringknaufschwert*, sword, weaponry, horse harness, Przeworsk culture, Early Roman period  
Received: 28.07.2021; Revised: 26.08.2021; Accepted: 20.11.2021

1 Muzeum Narodowe Ziemi Przemyskiej, Dział Archeologii i Przyrody, Pl. B. Joselewicza 1, 37-700 Przemyśl, Poland; sabinastempniak@wp.pl; ORCID: 0000-0002-7184-816X

2 Institute of Archaeology and Ethnology, Polish Academy of Sciences, Ślawkowska 17, 31-016 Kraków, Poland; anialasota80@gmail.com; ORCID: <https://orcid.org/0000-0002-0603-846X>

## GRAVE 50 FROM THE CEMETERY IN OSTRÓW

The growing number of Roman period sites excavated recently in south-eastern Poland is gradually starting to change the picture of cultural relations of the populations inhabiting this area. This region has been seen as particularly poor in finds of objects imported from the Roman Empire (Madyda-Legutko 1998, 29, fig. 1; Bochnak and Opielowska, in print). Archaeological sites recently discovered in the upper and middle San basin allow this view to be challenged. For example, in a necropolis explored in Prusiek, Sanok District, Site 25, as many as four of the 41 graves discovered contained imported Roman swords (Madyda-Legutko *et al.* 2007, 64). Situated in the same zone, the cemetery at Site 33 in Pakoszówka, Sanok District, yielded several objects of Roman provenance (Bulas *et al.* 2019, 97 and personal information). The ongoing comprehensive analysis of grave inventories from the cemetery at Site 21 in Ostrów (Przemyśl District, Podkarpackie Voivodeship), situated in the middle San basin, has revealed the presence of a number of important artefacts that were Roman imports. This applies, among other objects, to the four swords discovered there. Of particular note among them are a sword of the *Ringknaufschwert* type and the remaining objects discovered in Grave 50.

The cemetery in Ostrów is situated approx. 1 km from the San River. It occupies a left-bank terrace falling quite steeply to the SW, near a large bend in the San. Archaeological supervision of construction works in 2013 revealed a Przeworsk culture cemetery, resulting in a decision to conduct excavations (*cf.* Lasota and Stempniak 2015, 226; Lasota 2018; Lasota-Kuś and Stempniak-Kusy 2019, 78).

In the case of Grave 50, a poorly detectable outline of the grave cut was identified beneath the topsoil and subsoil layers at a depth of approximately 60 cm. Thus, the grave was dug deeper than the remaining burials in the site, with their ceilings typically recorded around a depth of 30 cm. At the level of discovery, a gold pendant was found in the central part of the pit. After some 10 cm of the fill was explored, the grave became a regular oval 105 × 80 cm in size. This top layer contained single sherds and tiny fragments of burnt human bone. Below, an urn was found, with numerous metal artefacts forming a cluster to the west of it. In cross-section, the grave resembled a hollow, some 40 cm deep and with clearly legible boundaries (Fig. 1). The fill was homogenous and consisted of soil of grey-brown colour. Inside the urn, two patinated flint blades, a fragment of an antler comb, and a bone pin were found among cremated human bones.

### GRAVE GOODS

1. Iron double-edged sword with crossbar and ring-like pommel, of the *Ringknaufschwert* type, intentionally broken in two. The blade is faceted in section, very long, tapering evenly towards the point. The point is short, ogival. The crossbar is rectangular is

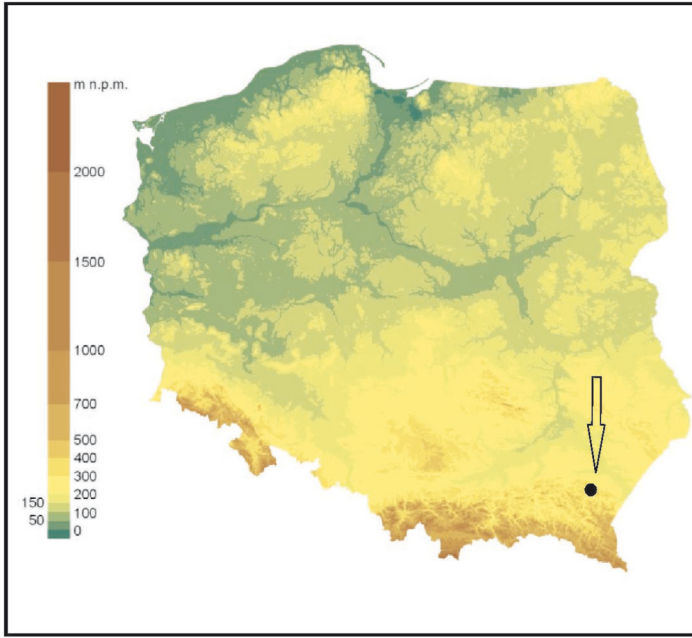

1

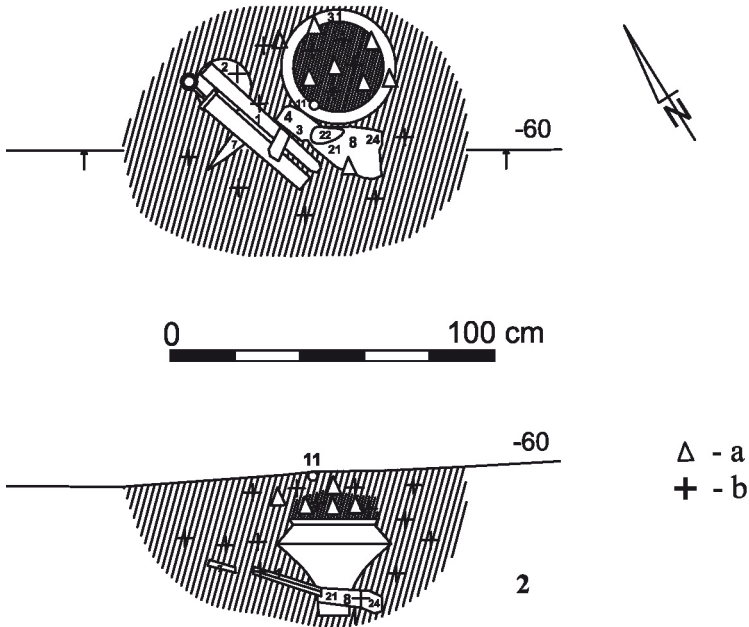

Fig. 1. Ostrów, Site 21. 1 – location of the site (drawn by Anna Lasota-Kuś),  
2 – Feature 50: plan and profile; a – pottery; b – cremated bones (drawn by Sabina Stempniak-Kusy)

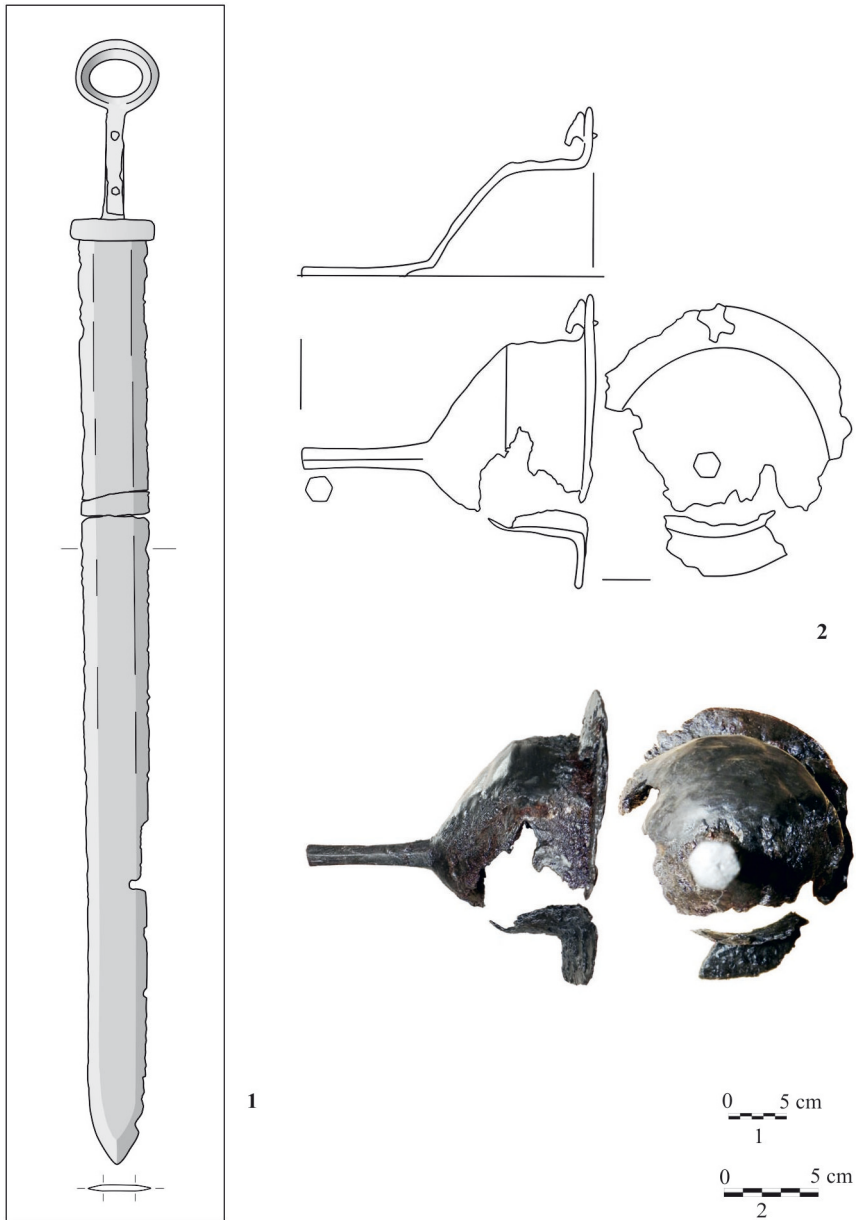

Fig. 2. Ostrów, Site 21, Feature 50 – metal elements of the grave furnishing  
 1 – iron sword of the *Ringknaußschwert* type), 2 – iron shield boss  
 (1 – illustrated by Marcin Biborski, 2 – illustrated by Urszula Socha)

section, and the oval ring, 7.0 × 5.8 cm and 1.1-1.5 cm thick, is attached to the tang with two rivets. Dimensions: total length of the sword: 96 cm; blade length: 77.8 cm; tang length: 23.1 cm; point length: 11.4 cm; width: 6.2-5.9 cm; weight: 725 g (Fig. 2: 1).

**2.** Iron shield boss, type 7a after M. Jahn (1916), with long, blunt spike, badly corroded and preserved fragmentarily. The spike is hexagonal in section, slightly narrowing in the middle part, 1.1 cm in diameter. The extant rivet has a flat, cruciform head made of sheet metal, approx. 2 × 2 cm in size, and the surviving length of the shaft is 1.1 cm; the other rivet had a trefoil head (it was damaged in conservation). Dimensions: boss diameter: approx. 16.5 cm; flange height: 4 cm; total height: approx. 15 cm, including spike height: approx. 6.2 cm (Fig. 2: 2).

**3.** Iron hafted weapon head, type VIII variant 3 after P. Kaczanowski (1995), bearing no traces of deliberate damage, with a massive blade and poorly marked spine, punched decoration, and with a very long round-sectioned socket slightly tapering towards the blade. Dimensions: length: 19.0 cm, including shaft length: 8.5 cm; blade width: approx. 3.4 cm (Fig. 3: 1).

**4.** Iron hafted weapon head, type XIII after P. Kaczanowski (1995), bearing no traces of deliberate damage, with a narrow blade with pronounced spine with the point broken off, and long round-sectioned socket slightly tapering towards the blade. Dimensions: preserved length: 27.0 cm (reconstructed length: 28.6 cm), including socket length: 10.5 cm; blade width: approx. 4.5 cm (Fig. 3: 2).

**5.** Iron shield grip of type 9 after M. Jahn (1916), fragmentarily preserved, with trough-shaped bar and trapezium-shaped rivet plates, with centrally placed rivets preserved. The rivets have small flat heads approx. 0.6 cm in diameter, and the surviving shaft lengths of 0.8 and 1.2 cm. Dimensions: bar width: 1.9 cm (Fig. 3: 3).

**6.** Iron scabbard slide (originally tied to the scabbard without using rivets), with the ends damaged. Dimensions: length: 12.9 cm; width: 2.3 cm (Fig. 4: 1).

**7.** Iron knife with the tang offset from both sides. Dimensions: tang length: 5.0 cm; reconstructed total length: approx. 15 cm (Fig. 4: 2).

**8.** Iron shears of type I after A. Knaack (1978). One blade is fully preserved and the other is partly preserved. One blade meets the bow at a right angle, and the other at an obtuse angle. Dimensions: blade length: approx. 9.0 cm; maximum blade width: 2.0 cm; maximum bow width: 1.0 cm (Fig. 4: 3).

**9.** Iron spur of type E2 after J. Ginalski (1991). Low, triangular-sectioned yoke with buttons for attachment. The shank is massive, full, and cone-shaped, octagonal in section. Dimensions: shank height: 1.7 cm; yoke span: approx. 5.2 cm; yoke height: approx. 1.5 cm; shank base dimension: 1.5 cm (Fig. 4: 4).

**10.** Iron trapezium-shaped bar, perhaps fragment of a firesteel. Dimensions: width: 1.6 cm; length: 9.7 cm (Fig. 5: 1).

**11.** Pelta-shaped pendant made of thin electrum foil (gold 60%, silver 38.94%), in the shape of an elongated rectangle whose one narrower end had the corners cut into an

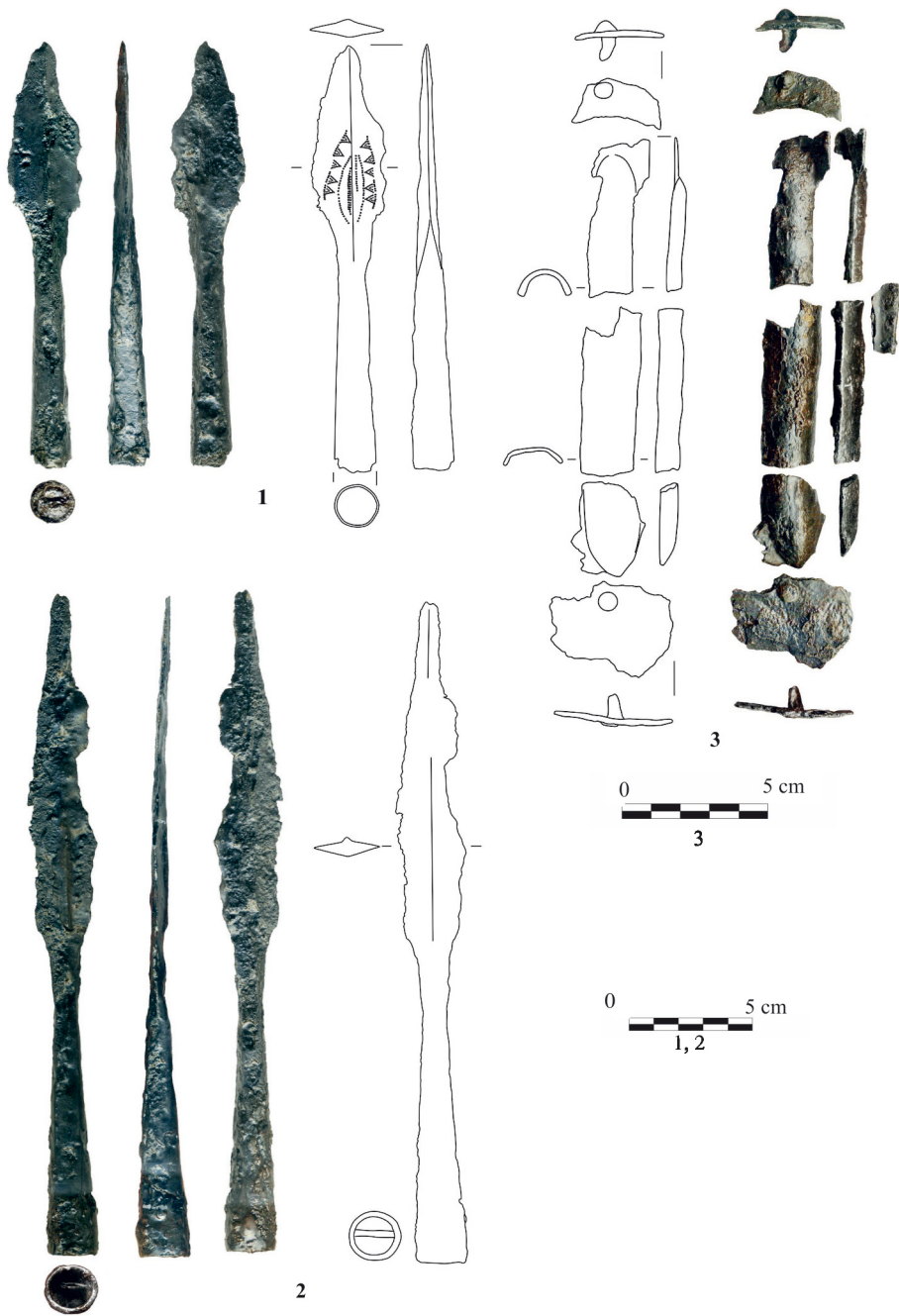

Fig. 3. Ostrów, Site 21, Feature 50 – metal elements of the grave furnishing.  
1-2 – iron spearheads, 3 – iron shield grip (illustrated by Urszula Socha)

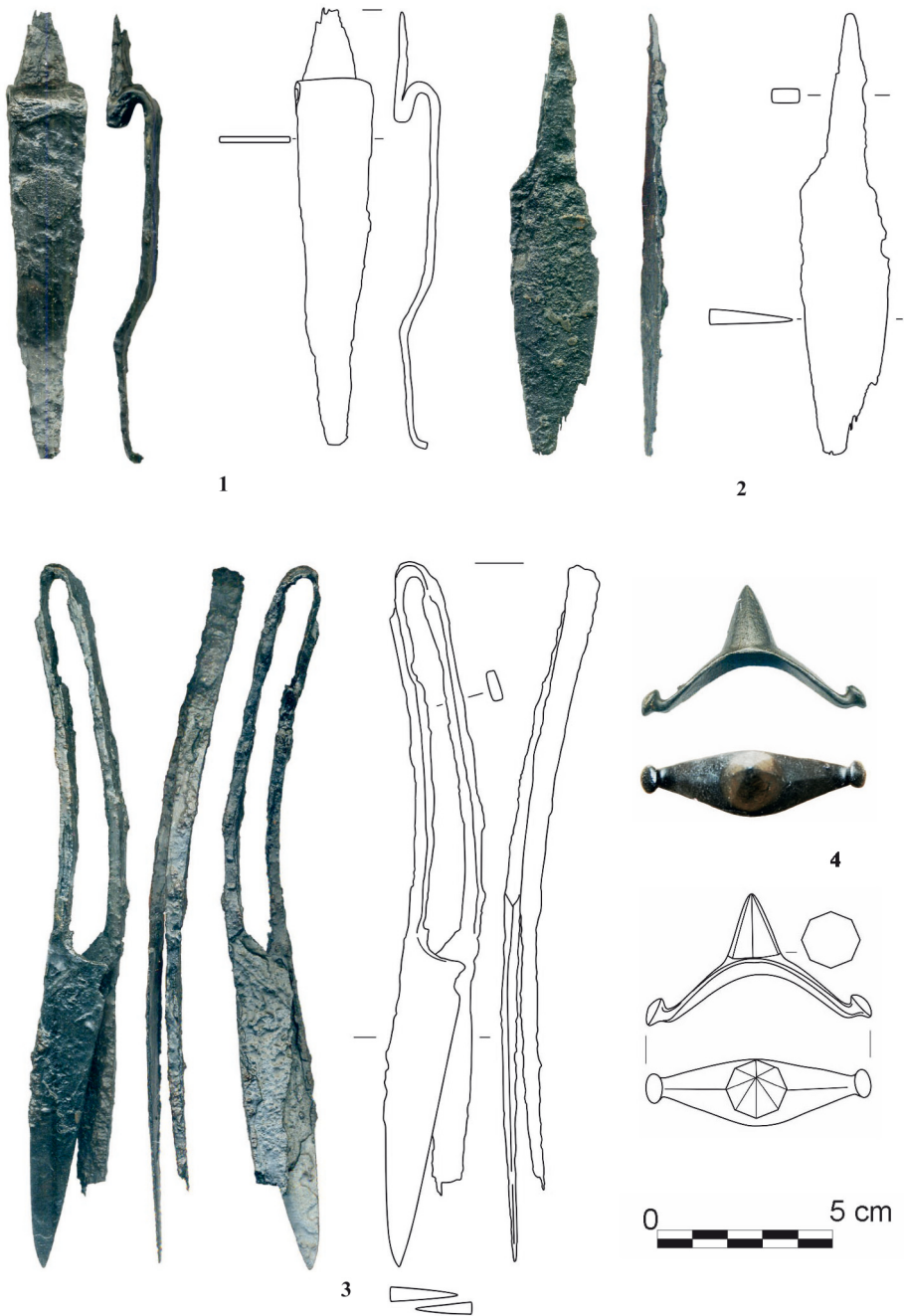

Fig. 4. Ostrów, Site 21, Feature 50 – metal elements of the grave furnishing.  
 1 – sword scabbard pendant, 2 – iron knife, 3 – shears, 4 – iron spur (illustrated by Urszula Socha)

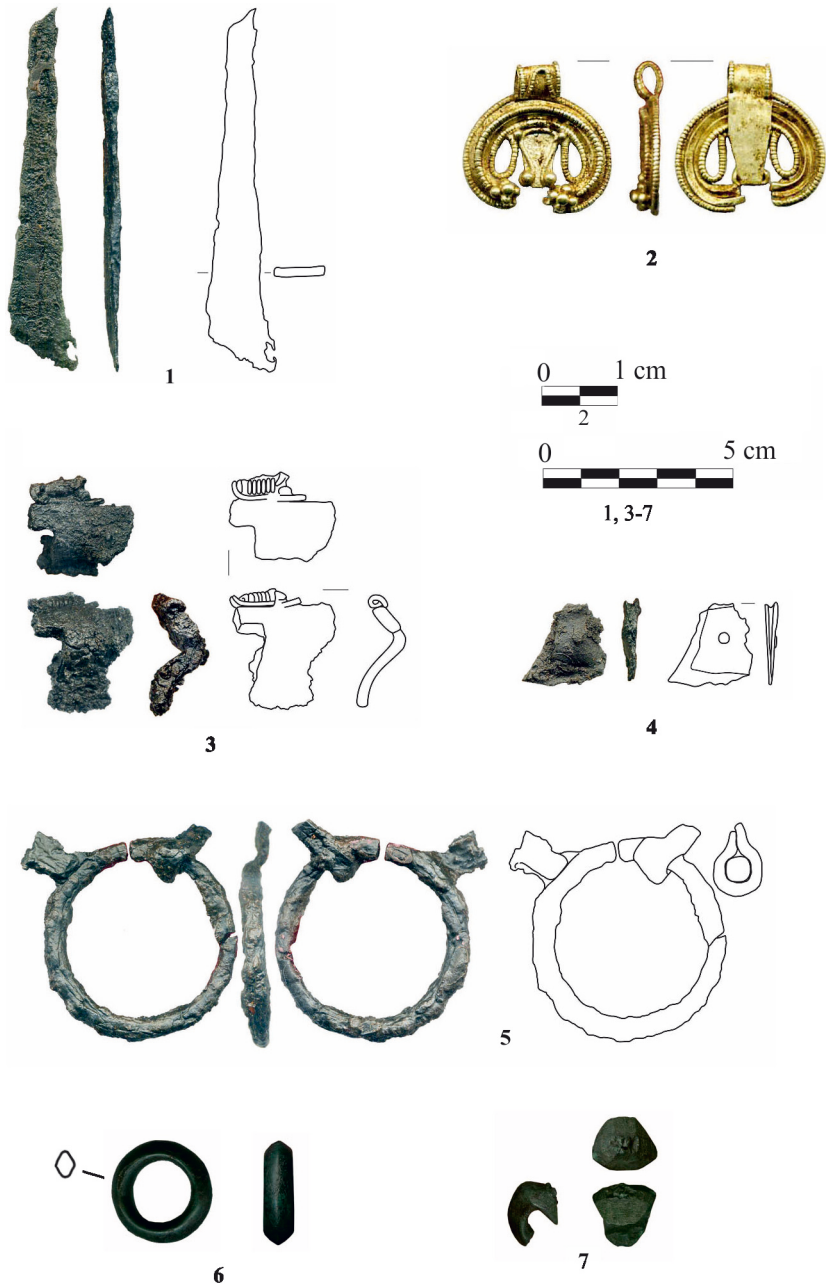

Fig. 5. Ostrów, Site 21, Feature 50 – metal elements of the grave furnishing. 1 – iron fire striker (?), 2 – electrum pendant, 3 – iron fibula, 4 – fragment of a belt fitting (?), 5 – iron bit, 6 – bronze ring, 7 – bronze fragment of horse harness (illustrated by Urszula Socha)



isosceles trapezium, while the other end was rolled into a loop. The middle part of the rectangular plate had two very thin ribbons of gold foil soldered to it, which were then bent into an arch forming the pendant's arms. This entire construction was then used as a framework to which tiny filigree wires, twisted and hammered down, were soldered. They were placed along the edge and on top of the pendant's arms, and along the edges and in the middle of the loop, where the decoration resembles the Greek letter omega in shape. The centre of the rectangular plate was decorated in the same manner. The ends of the wires were adorned with single granules. The pendant is slightly asymmetrical, leaning to the right-hand side. Dimensions: 2.0 × 1.8 cm; weight: 3.34 g (Fig. 5: 2).

**12.** Iron brooch of Leonów type, badly corroded, with partly preserved spring, with ribbon like bow; the pin and catchplate have not survived. Dimensions: preserved length: 3.0 cm (Fig. 5: 3).

**13.** Fragment of what possibly was a belt fitting comprised of two thin iron plates connected by a rivet. Dimensions: 1.5 × 1.7 cm and 2.4 × 2.1 cm (Fig. 5: 4).

**14.** Elements of horse harness:

a) Fragment of an iron bit – a round bit rings and their ferrules. Dimensions: wire thickness: 0.6 cm; outer diameter of the ring: 5.3 cm; inner diameter: 4.2 cm (Fig. 5: 5).

b) Bronze ring, rhomboidal in section, slightly rounded from the inside (perhaps due to use-wear). Dimensions: outer diameter: 2.7 cm; inner diameter: 1.6 cm (Fig. 5: 6).

c) Fragment of a bronze object bent into a hook, faceted in section, with one end damaged (broken off). Dimensions: height: 1.6 cm; width: 1.5 cm (Fig. 5: 7).

d) Iron fitting. A massive artefact with a ribbon-like semi-circular bow passing into two broad plates set parallel to each other (both are rectangular in outline, with rounded corners) and bound with two rivets with flat, round heads 0.7-0.8 cm in diameter. The bow is round-sectioned, 0.7 cm in diameter. Dimensions: length: 6.6 cm; width: 4.0 cm (Fig. 6: 1, 1a).

e) Iron fitting. A massive iron object with a semi-circular bow passing into two broad plates set parallel to each other (one rectangular in outline, the other triangular with rounded corners) and bound with a single rivet with a flat, round head and a thick shaft; the bow is round-sectioned, 0.8 cm in diameter. Dimensions: length: 7.6 cm; width: 3.5 cm (Fig. 6: 2, 2a).

**15.** Fragment of an iron fitting consisting of two plates bound with a rivet with a massive round head. Dimensions: rivet head: 1.5 × 1.1 cm; plates: 2.1 × 2.3 × 0.2 cm and 3.1 × 1.7 × 0.2 cm (Fig. 7: 1).

**16.** Bronze rivet, type F after Zieling (1989), with a domed head and a round-sectioned shaft. Dimensions: head diameter: 11.4 cm; shaft diameter: 0.2 cm; preserved shaft length: 0.6 cm (Fig. 7: 2).

**17.** Iron buckle with a simple, rectangular frame with a groove running along its entire perimeter, with the base of the prong wound around the frame (after conservation, only a fragment of the frame has survived, without the prong). Dimensions: 5.2 × 4.2 cm.

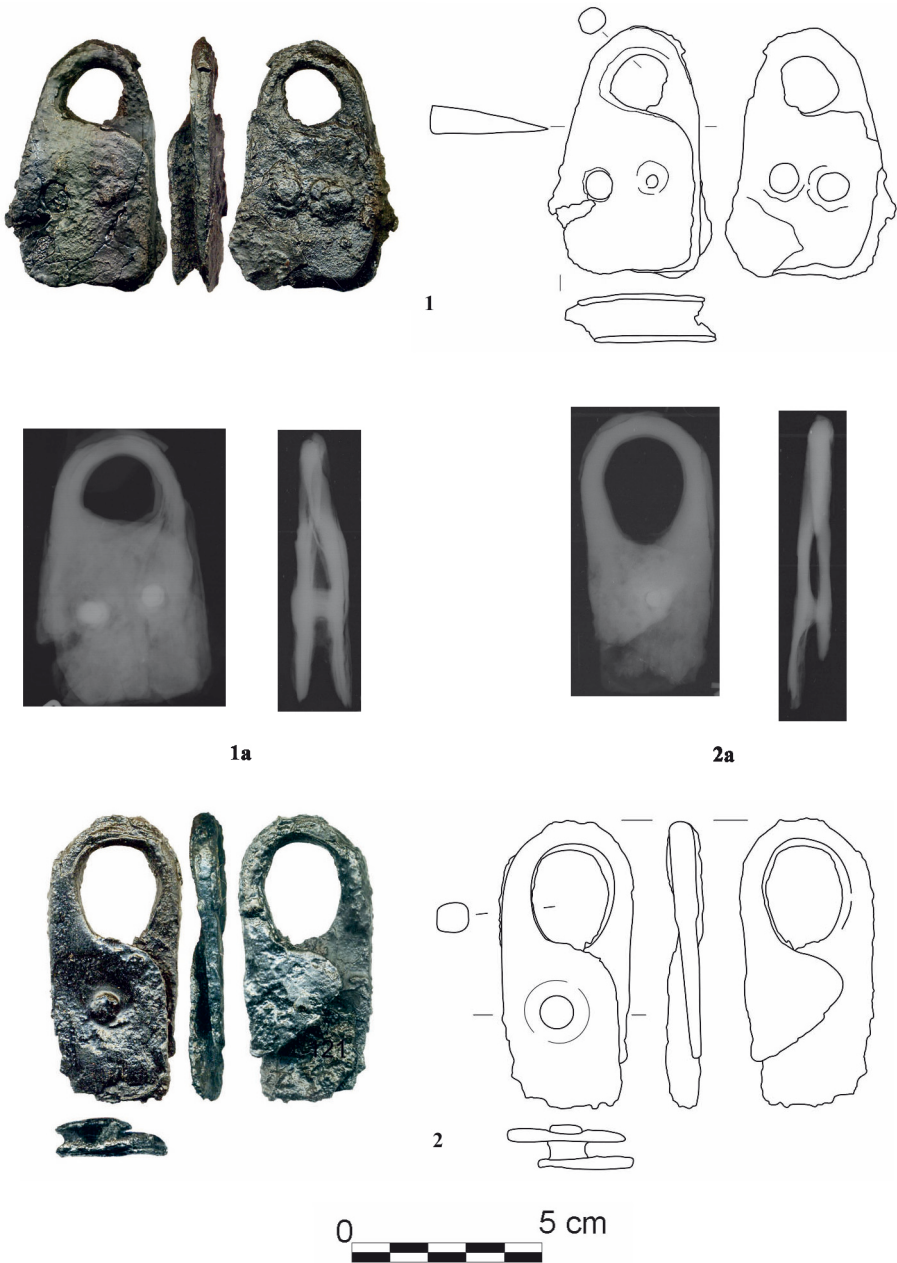

Fig. 6. Ostrów, Site 21, Feature 50 – metal elements of the grave furnishing.  
 1-2 – iron elements of horse harness (X-ray photos made by Władysław Weker, X-ray Laboratory of the State Archaeological Museum in Warsaw; illustrated by Urszula Socha)

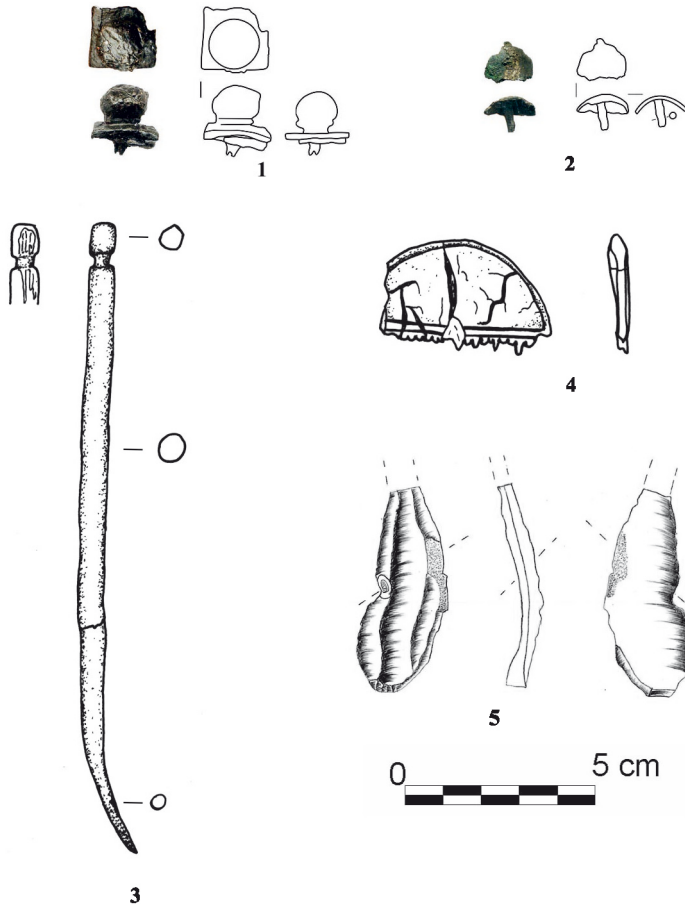

Fig. 7. Ostrów, Site 21, Feature 50 – metal elements of the grave furnishing. 1 – fragment of iron fitting with rivet, 2 – bronze rivet, 3 – bone pin, 4 – antler horn, 5 – flint blade (1-2 – illustrated by Urszula Socha; 3-4 – illustrated by Anna Lasota-Kuś; 5 – illustrated by Wojciech Mika)

**18.** Trapezium-shaped sandstone whetstone. Dimensions: length: 10.2 cm; width: 4.2 cm.

**19.** Fragment of a round-sectioned iron wire. Dimensions: length: 2.6 cm; diameter: 0.5 cm.

**20.** Fragment of a ribbon-shaped iron object, rectangular in section, fragmentarily preserved.

**21.** Fragment of a fitting made of sheet bronze, with 0.3 cm-wide edges bent, with a hole for a rivet.

**22.** Two bronze sheet fragments, one with a rivet shaft embedded.

**23.** Iron rivet with a round head and a 1.6 cm long shaft.

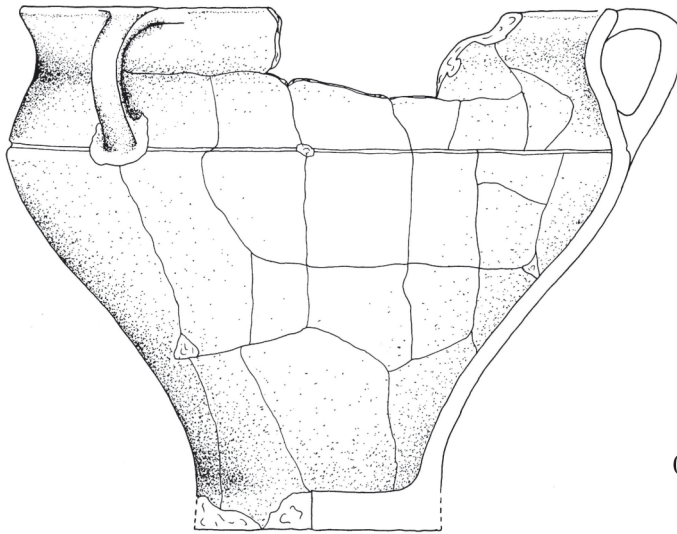

1

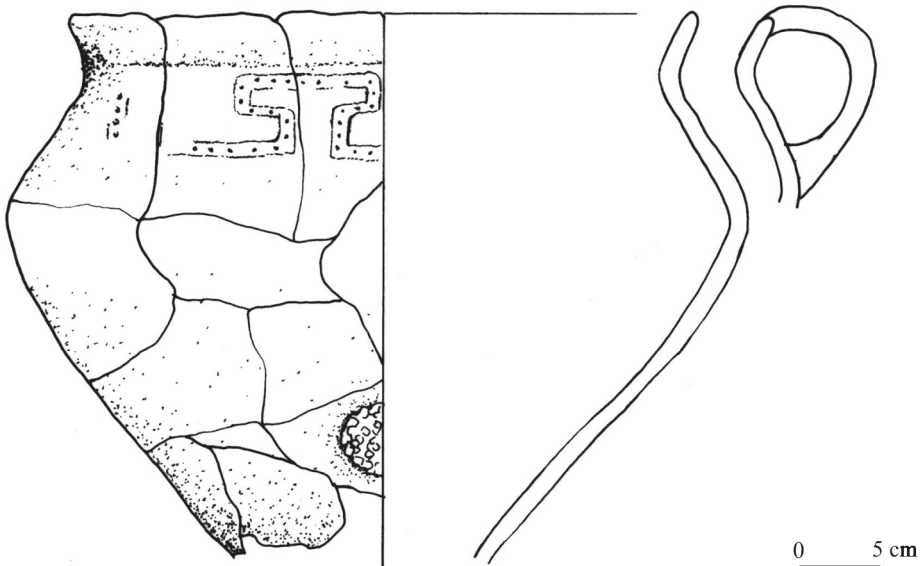

2

Fig. 8. Ostrów, Site 21, Feature 50 – clay vessels (illustrated by Anna Lasota-Kuś)

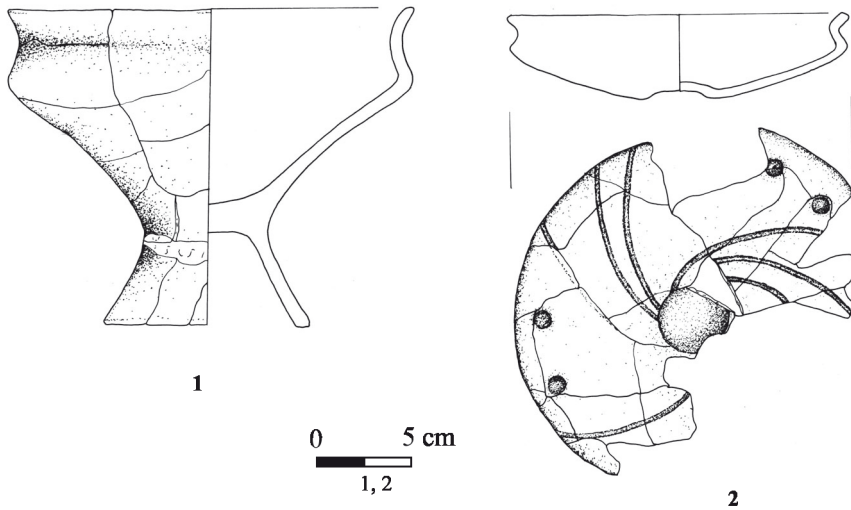

Fig. 9. Ostrów, Site 21, Feature 50 – clay vessels (illustrated by Anna Lasota-Kuś)

**24.** Three fragments of iron sheet with two rivets (perhaps fragments of a shield grip), Dimensions: 5.1 × 6.5 × 0.1 cm; rivet heads are round and domed, 0.6-0.7 cm in diameter.

**25.** Fragment of an iron object. Dimensions: 2.4 × 1.0 cm.

**26.** Fragments of a fitting made of thin iron sheet, with a rivet. Dimensions: 2.7 × 2.7; 3.9 × 3.1; 2.0 × 1.0; 2.3 × 1.5; 2.3 × 2.1 cm; thickness: 0.1 cm.

**27.** Bone pin with a slightly bent shaft and pronounced head, slightly faceted in section. Dimensions: length: 16.9 cm (Fig. 7: 3).

**28.** Burnt antler comb of Thomas type IA. Dimensions: width: 4.5 cm (Fig. 7: 4).

**29.** Flint blade, heavily burnt. Dimensions: length: 4.4 cm; width: 2.4 cm (Fig. 7: 5).

**30.** Burnt flint blade, preserved in two fragments. Dimensions: length: 5.4 cm; width: 1.9 cm.

**31.** Ceramic vessels (all of them handmade):

a) Vase (urn) of type II/3 after T. Liana (1970), fully preserved, with everted rim, with the maximum body width clearly pronounced and emphasised by a circumferential incised line, and placed slightly above the middle of the vessel's height; base distinctly smaller than the rim in diameter; the vase has three knee-like handles; the surfaces are smooth, blackened, matt, and the ceramic fabric has no discernible temper. Dimensions: rim diameter – 32 cm; base diameter – 13 cm; height – 27.5 cm (Fig. 8: 1).

b) vase of type II after T. Liana (1970), secondarily burnt to a significant degree, with everted rim, with the maximum body width clearly pronounced; the base part is missing; the vessel has one ribbon handle; decoration in the form of a poorly legible symmetrical

meander made of bands of incised lines filled with hollows can be seen on the shoulder; mottled surfaces of brown-grey colour, with pieces of melted glass adhering in places to the inner and outer walls (probably remains of a glass vessel), ceramic fabric tempered with sand. Dimensions: rim diameter – 28 cm (Fig. 8: 2).

c) vase on a high, hollow foot, slightly secondarily burned, nearly complete, with slightly everted rim and the maximum body width clearly pronounced and located above the mid-height; surfaces are smooth and brown; no discernible temper. Dimensions: rim diameter – 21.5 cm; base diameter – 11 cm; height – 16.8 cm (Fig. 9: 1).

d) fragments of a bowl of type VI/2 after T. Liana (1970), slightly secondarily burnt, incomplete, with everted rim, sharply profiled body, and concave base; the body is decorated with groups of three arched incised lines, with the groups separated from each other by two hollows; mottled surfaces of brown-grey colour, no temper discernible in the ceramic fabric. Dimensions: rim diameter – 18 cm; height – 4.5 cm (Fig. 9: 2).

e) fragments of a bowl of type VI/2 after T. Liana (1970), strongly secondarily burnt, deformed, incomplete, with everted rim, strongly profiled body, and slightly rounded base; the surfaces are smooth, mottled, of brown-grey colour, no discernible temper in the ceramic fabric. Diameter: approx. 12 cm.

f) fragments from the lower part of a secondarily burnt vase with the base formed into a high foot with a circumferential rib; the surfaces are smooth, no discernible temper.

g) several sherds, strongly secondarily burnt, including a tiny fragment of a vessel with an everted, rounded rim and smooth, mottled surfaces of brown-grey colour, with no temper discernible in the ceramic fabric.

h) body sherd from a medium-walled vessel with coarse surfaces of grey colour; abundantly tempered with medium-grained crushed stone.

i) body sherd from a medium-walled vessel with coarse surfaces of brown colour, sparsely tempered with medium-grained crushed stone.

j) eight tiny, burnt sherds originating from different vessels, with brown and grey surfaces.

**32.** Burnt human bones (1306 g) of an adult male.

## ANALYSIS OF THE MATERIAL

### Weaponry and equestrian equipment

Among the grave goods uncovered in Grave 50, the iron double-edged sword with the grip terminating in a ring and with a rectangular, bar-like crossbar is a unique find. The slightly oval ring, rhomboidal in section, was attached to the tang with two rivets. The sword had been intentionally broken in two and placed next to the urn along with the rest of the furnishings.

Swords of this kind are described in the literature as *Ringknaufschwerter* and are thought to have been products of Roman workshops (Kaczanowski 1992, 27, 28). Other than by their ring-like pommels, these swords do not differ from other weapons of that period, and in typological terms most of them are classed as a gladius, semi-spatha, or spatha (Miks 2017, 118). According to the classification by M. Biborski, the sword from Ostrów should be included in type I of swords with ring-like pommels, dated to phase B2 of the Early Roman period and phase C1 of the Younger Roman Period (Biborski 1994, 86, 87) and sometimes referred to as the Počaply-St. Margrethen type (Biborski 2020, 416). It is worth noting the dimensions of the specimen in question, unique on the European scale for a weapon of that type. While most such swords do not exceed 80 cm in length, the one from Ostrów is no less than 96 cm long.

Roman swords with ring-like pommels are exceptionally rare finds in Przeworsk culture materials. Previously, the only specimen known from the territory of Poland was that discovered in the cemetery at Site 1 in Krupice, Siemiatycze District, in Grave 106 dated within phases B2b-B2/C1 (Biborski *et al.* 1997; Jaskanis 2005, 32, 95, pl. 28: 1). Another sword of the discussed type comes from the Przeworsk culture cemetery in Rankovce, okr. Košice, in south-eastern Slovakia. It was found there in Grave 4, which held the burial of a warrior furnished, among other objects, with what is described as a complete set of weaponry. Apart from the sword, the set included a shield and a spear. As in Ostrów, this was probably the grave of a mounted warrior, as indicated by the presence of two iron spurs (Rákoš 2019, 220).

A *Ringknaufschwert* was also found in a warrior grave in the cemetery in Sekule, okr. Senica, south-western Slovakia (Rajtár *et al.* 2019, 131), where the bulk of the graves date within phases B2-C1. In the Roman period, this area was primarily inhabited by the Quadi. However, it has been demonstrated that a number of artefacts from the Sekule cemetery reveal links with the northern reaches of Central European *Barbaricum*, including with the Przeworsk culture. Graves furnished with such artefacts should be seen as reflecting migrations from the aforementioned areas during the Marcomannic Wars (Rajtár *et al.* 2019, 133).

A recent examination of a *Ringknaufschwert* found on the agora of Paphos, Cyprus, produced interesting results. The analysis indicated that the characteristic Roman pommel had been attached to a blade that most likely was a barbarian product. It was even hypothesised that the sword's owner might have been a warrior originating from the Przeworsk culture area (Biborski 2020, 416).

There is a view in the literature that the impetus for the appearance of swords with ring-like pommels of the discussed type in the Roman army came from contacts with the Sarmatians, who used similar swords (Biborski 1994, 90, 91). Perhaps the design was adopted during the Dacian wars of Emperor Trajan, in which Sarmatian tribes were also involved (Sadowski 2004, 275). However, the Roman version of the grip was not a direct copy of the Sarmatian weapons. As mentioned, the ring was forged independently and

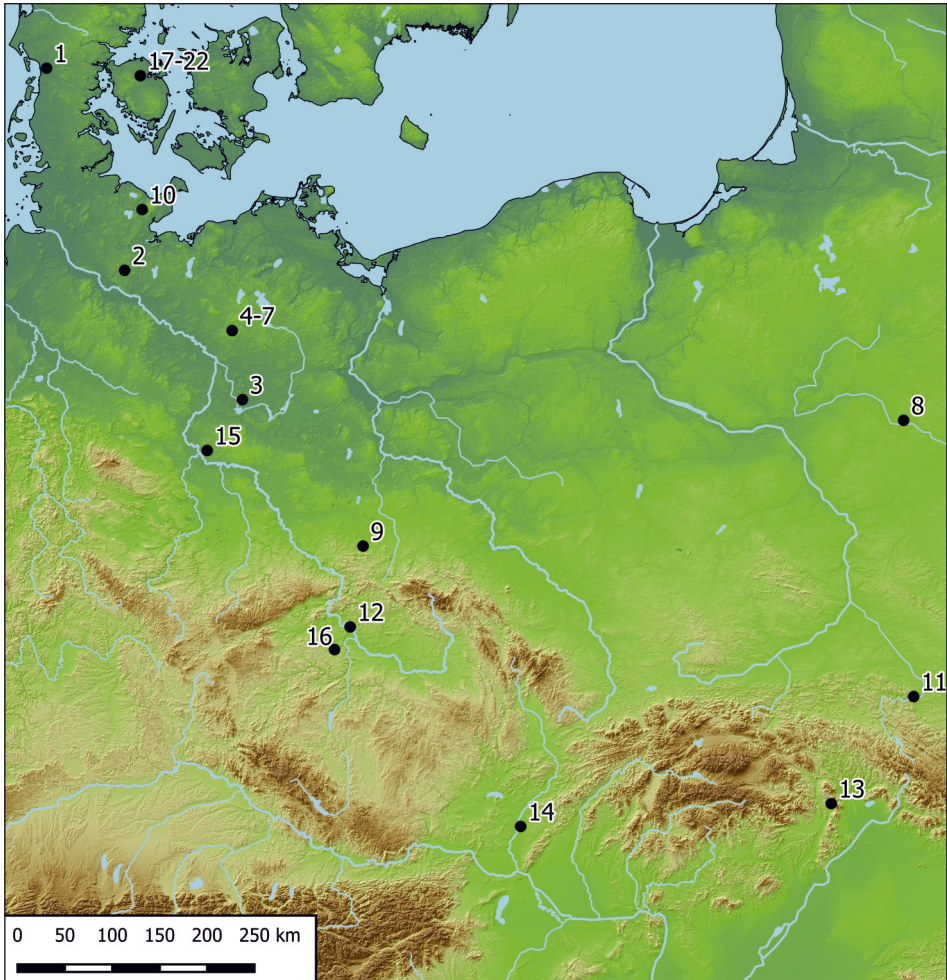

Fig. 10. Distribution of *Ringknaufschwert*-type swords in *Barbaricum*.

1- Brokjaer Mark, Hjortlund, Ribe, grave (Raddatz 1961, 32, fig. 5: 3), 2 – Hamfelde, Kr. Herzogtum Lauenburg, Grave 665 (Bantelmann 1971, 162, pl. 96), 3 – Hohenferchesar, Kr. Westhavelland, grave (Raddatz 1961, 36, fig. 8: 4), 4-7 – Kennitz, Kr. Potsdam-Land, Grave 430, 455, 508 and destroyed Graves 589-593 (Geisler 1974, 50, 53, 58, 67, pl. 39, 43, 48, 57), 8 – Krupice, Siemiatycze District, Grave 106 (Jaskanis 2005, 95, l. 29: 1), 9 – Litten, Kr. Bautzen (Meyer 1971, 144, fig. 80), 10 – Malente-Krummsee, Kr. Ostholstein, Grave 79 (Raddatz 1961, 28, fig. 1: 1), 11 – Ostrów, Przemyśl District, Grave 50, 12 – Počaply, okr. Melník (Schranil 1928, fig. 9: 6), 13 – Rankovce, okr. Košice, Grave 4 (Rákoš 2019, 220, fig. 3), 14 – Sekule, okr. Senica, Grave K (Rajtár *et al.* 2019, 131), 15 – Töppel, Kr. Zerbst (Mildenberger 1949, 25, fig. 1), 16 – Třebusice, okr. Kladno, grave (Keller 1966, 196), 17-22 – Vimose, Odense, Funen, swamp find (Engelhardt 1869, pl. 19: 5; Hundt 1953, 109, 110, pl. 8: 3-7; Kaczanowski 1992, 85) (illustrated by Aleksandra Sznajdrowska-Pondel and Anna Lasota-Kuś)



attached to the tang with rivets, meaning it could be attached to any type of blade (Miks 2017, 118). The sword from Paphos provides a perfect illustration here.

In *Barbaricum*, most of the *Ringknaufschwerte* appeared during the Marcomannic Wars in the northern part of the Elbe Germanic complex, Schleswig-Holstein, and Denmark (Raddatz 1961, 26ff; Kaczanowski 1992, 27-30), as well as in the Czech Republic (Droberjar 1999, 5, pl. 17) (Fig. 10). At least one specimen is known from the Hamfelde cemetery in Schleswig-Holstein, from Grave 665 (Bantelmann 1971, pl. 96: 665a), while those discovered in Graves 277, 302, and 403 are considered Germanic imitations (Bantelmann 1971, 23, 112, 115, 129, pl. 36: 277a, 40: 302g, 61: 403a; Kaczanowski 1992, 27, 28).

In the analysed Grave 50 from Ostrów, the sword was accompanied by an iron ribbon-like scabbard pendant, which makes a Roman provenance of the scabbard likely (Fig. 4: 1). The pendant finds closest analogies in Kaczanowski's type VI of scabbard slide, occurring in the Central European *Barbaricum* during phases B2 and C1 (1992, 40, 41, fig. 10: 2).

The grave also contained shield parts: a boss and a grip. The boss, with a blunt spike, represents type J7a1 after T. Liana (1970) (Fig. 2: 2). It is worth noting the presence of rivets of different head shapes: one cruciform and one resembling a trefoil. This difference can be assumed to reflect repairs, possibly involving the replacement of rivets. Boss and grip rivets with cruciform or star-shaped heads are extremely rare in the Przeworsk culture area. Such rivets were found with a J7a boss in Grave 20/1938 in Tarnów, Opole District, Site 3 (Godłowski and Szadkowska 1972, pl. 29: 8), and rivets with irregularly formed heads nearing the shape of a cross were found with a conical boss from Grave 82 at Site 1 in Opatów, Kłobuck District, dated very precisely to phase C1a (Madyda-Legutko *et al.* 2011a, 46; 2011b, pl. 11: 12).

The shield grip discovered in Grave 50, with separated plates and with preserved rivets with small, round, flat heads, represents type J9, particularly characteristic of the developed stage of phase B2 (Liana 1970, 453; Godłowski 1992, 72).

The hafted weapon heads from Grave 50 differ significantly in size (Fig. 3: 1, 2), which probably indicates their different functions (one belonged to a spear and the other to a javelin). It has been observed that the custom of placing two different heads in a grave is especially clear in phase B2b (Kontny 2019, 29). The larger specimen (29 cm) represents type XIII in Kaczanowski's classification. Such artefacts essentially occur in the developed stage of phase B2 and are incidentally found in assemblages from the beginnings of the Younger Roman period (Kaczanowski 1995, 22).

The second head, smaller, belongs to type VIII variant 3 acc. to Kaczanowski, occurring in assemblages from the developed stage of phase B2, but sometimes also in phase C1a (Kaczanowski 1995, 19, 63, pl. 9: 5). On one side of the blade, near the centre, there is a decoration in the form of punched isosceles triangles pointing towards the spine and framed by punched semicircles. Traces of lines (one single and one double) have also survived along the spine. In the past, the ornament of negative triangles tended to be interpreted in the literature as a manifestation of Wielbark culture influences in the eastern

zone of the Przeworsk culture (Kaczanowski and Zaborowski 1988, 236). This view was recently challenged based on new finds that confirmed that spearheads with such decoration also occurred in the western range of the Przeworsk culture and in the Baltic area. The specimen from Ostrów is most akin to Kontny type 1 (Kontny 2017, 195, 198, 199 – here a full list of spearheads decorated with negative triangles), whose chronology was determined as phase B2b and the very beginning of the Younger Roman period (Kontny 2017, 198).

The iron spur of Ginalski type E2 found in Grave 50 is characteristic of phase B2 of the Early Roman period and phase C1a of the Younger Roman period (Ginalski 1991, 62). It should be noted that it was precisely at the beginning of the Younger Roman period when the custom of placing spurs in a grave reached the peak of its popularity in the Przeworsk culture, and these were most often single specimens, as in Ostrów (Kontny 2009, 100-102).

### Elements of horse harness

As mentioned above, the objects found in the discussed grave from Ostrów included elements of horse harness. It needs to be emphasised that such artefacts are very rare finds in graves of Przeworsk culture warriors (*cf.* Kontny 2009). In the developed stage of the Early Roman period and in the Younger Roman period, the custom of placing horse tack pieces in male burials was popular in the Sarmatian milieu. The contacts between the Przeworsk culture population and this milieu have already been confirmed in the literature (Dobrzańska 1999).

The iron ring with fragmentarily preserved ribbon fittings (Fig. 5: 5) found in Grave 50 should be interpreted as a fragment of a horse bit. It refers to the type 2C of M. Ørsnes (1993). Similar forms, made of non-ferrous metals, are known from the bog site in Thorsberg (Lau 2014, pl. 4-7). Fragments of a bit of similar construction were found in the burial of a Sarmatian warrior from Kobyakovo on the lower Don River, dated to the second half of the 2<sup>nd</sup> century AD (Guguev and Bezuglov 1990, fig. 3: 8-10).

The two massive iron fittings in the form of a bow passing into two plates bound by rivets (Fig. 6: 1, 2), interpreted as elements of horse harness, find no analogy among Przeworsk culture material. Somewhat similar artefacts incidentally occur in Sarmatian sepulchral assemblages, with examples known from the Great Hungarian Plain, among other places. In male Grave 28 in Hévízgyörk, Pest District, analogical fittings co-occurred with other elements of horse harness, including a bit (Dinnyés 1991, pl. 14: 18; 15: 17). In addition, two such fittings made of bronze were discovered in Barrow Grave no. 4 in Vizedpuszta (today Vizejdia, Romania), where the grave goods also included a sword and elements of horse harness (Vaday 1986, fig. 1.1: 15, 16). Outside the Great Hungarian Plain, in the Sarmatian milieu such artefacts also occur in graves of warriors from the Azov cemetery in the lower Don basin, which are dated to the close of the 2<sup>nd</sup> century and the early 3<sup>rd</sup> century AD (*cf.* Istvánovits and Kulcsár 2003, 232, fig. 5: g). This group of burials defines a specific Hévízgyörk-Vizedpuszta-Azov horizon of archaeological finds, dated to the second

half of the 2<sup>nd</sup> century to the third quarter of the 3<sup>rd</sup> century AD (Grumeza 2016, 446-448), which in terms of relative chronology of Central European *Barbaricum* corresponds to Eggers' (1955) phases C1a-C2. Apart from the area discussed above, analogical artefacts are known from the 3<sup>rd</sup>-century AD Grave 222 in Neyzas cemetery in Crimea, where they were found among other elements of horse harness (Khrapunov 2006, fig. 2: 18, 19).

Referring to the discussed fittings, Hungarian archaeologists use the term "harness buckle without spike". According to reconstructions created by A.H. Vaday, they belonged to a leather strap being part of a bridle (Vaday 1986, fig. 6: 7). It is worth noting, however, that the finds from Ostrów were more massive, so they may have had some other function in horse harness.

It is also worth noting two small artefacts of analogical construction discovered in the princely grave in Mušov in Moravia. They escaped the attention of the authors who published that assemblage, although a drawing of one of them features in one of the plates (Peška 2002, fig. 7c: G18). Apparently, they were mistakenly interpreted as elements of furniture (Peška 2002, 14 – here as ivory artefacts). However, in light of the above, they should likely be seen as horse harness pieces of Sarmatian provenance. In this context, it is worth noting that three artefacts from the Mušov grave, two belt appliques and a spear-head, feature motifs that were recently proposed to be interpreted as Sarmatian tamgas (Voroniatov 2012, 185-189).

Another artefact probably related to horse harness is the bronze ring of roughly rhomboidal section (Fig. 5: 6), akin to type 2a of horse harness rings in Wilbers-Rost's (1994) classification. According to Wilbers-Rost, such rings, while very rarely found, should essentially be linked with phase C1 of the Roman period (Wilbers-Rost 1994, 57). The small fragment of unidentified bronze object of faceted section may perhaps also be an element of horse harness (Fig. 5: 7).

## Ornaments, dress items and personal equipment

The analysis of the chemical composition of the richly decorated pelta-shaped pendant revealed that the artefact is made of electrum (gold 60%, silver 38.94%; the analysis was performed by M. Biborski in the Laboratory of Archaeometallurgy and Conservation, UJ Institute of Archaeology).

Such artefacts are referred to in the literature alternatively as kidney-shaped (Pinar *et al.* 2007, 580; Krupiewski and Lewandowska 2013, 186), heart-shaped (Rudnicki 2009, 422), crescent, or pelta-shaped pendants (Tempelmann-Mączyńska 1986, 378; Rodzińska-Nowak *et al.* 2021), or lunulas (Biborski and Kazior 1997, 115). Each of them has its individual shape and decoration, and it is difficult to find two similar pieces. Pelta-shaped, three-way/horned lunulas are known throughout Europe, as far as the Urals (Åberg 1919, 102, 103; Kropotkin 1978, 157; Shukin and Sherbakova 1986, 198, 199; Tempelmann-Mączyńska 1986; Werner 1988, 275-277; Ambroz 1989, 100, 118, 120; Kargopoltsev and

Bajan 1993; Rudnicki 2009). As with other crescent ornaments, they are dated from the Roman to Early Medieval period (*cf.* recently Rodzińska-Nowak *et al.* 2021 – with complete literature for sites from the territory of Poland).

It is worth mentioning that Roman-period electrum artefacts are very rare finds in Poland (Madyda-Legutko *et al.* 2010, fig. 2; Natuniewicz-Sekuła 2020, 40). In this context, their relative concentration in south-eastern Poland is noteworthy. Apart from the artefact from Ostrów, a spherical pendant and another one in the shape of an axe were discovered in the Gać cemetery in Przeworsk District, Site 1 (Lasota-Kuś and Madyda-Legutko 2018, 298, 301).

The position of the pendant in the grave, at some distance from the remaining artefacts, and the absence of any mechanical or thermal damage (revealed by other elements of the grave assemblage) may indicate that the artefact did not belong to personal equipment of the deceased, and was instead a kind of gift from the world of the living (Madyda-Legutko *et al.* 2005, 185; Błażejowski 2007, 101, fig. 64; Skóra 2008, 7). There is a view in the literature positing that the Roman period gold pendants known from Poland were indicators of high social status (Rodzińska-Nowak *et al.* 2021, 350).

The iron ribbon-like brooch should be seen as a specific variant of group V series 11, known as the Leonów type (Fig. 5: 3). This type is regarded as a form characteristic of the western range of the Przeworsk culture, where such brooches occur primarily in warrior graves dated to the close of phase B2 (Jamka 1963, 70ff; Godłowski 1977, 22f).

The antler comb found inside the urn (Fig. 7: 4) represents type IA in S. Thomas's (1960) classification, very common in Przeworsk culture grave inventories. On both sides, it is decorated with two parallel incised lines above the teeth, and a single incised line runs along the edge. Combs of the discussed type essentially occur in the Early Roman period (Liana 1970, 450).

It is worth noting that the bone pin, also found inside the urn, does not bear clear traces of burning (Fig. 7: 3). Its potential exposure to fire is only indicated by insignificant bending of the shaft. This is a massive specimen with a slightly faceted head, which finds no parallels in the typology of bone and antler pins developed by A. Dulkiwicz (2009). It shows some resemblance to the massive pins from the settlement in Jakuszowice Site 2 (Godłowski 1991, 670, fig. 5: 7-9), although the context in which the latter was discovered points towards a different chronology.

The two burnt flint blades found inside the urn had probably been deliberately placed there. The question of fragments of flint tools, flint blades and flakes appearing in Roman period sites has recently been addressed in the literature in the context of the discussion of such finds originating from graves from the Neżzac cemetery in Crimea. The results of that research, which included traseological analyses, indicate that those flint objects were used for striking fire (Mączyński and Polit 2016, 187-190), and this is how we should probably interpret the finds from Grave 50 in Ostrów as well. Grave 50 also contained a fragment of a bar-like firesteel, probably part of a fire-striking set together with the flint blade. In the

Przeworsk culture, a set consisting of a flint blade and an iron firesteel has so far been found in the cemetery in Czarnocin, Piotrków Trybunalski District, in Grave 8 dated to phases B2/C1-C1a (Mączyńska and Jagusiak 2002, 356, 360, pl. 4: 21, 22) as well as in the cemetery in Zapowiednia, Września District in Grave 2, belonging to this same chronological phase (Ciesielski 2008, 270).

Another noteworthy find from Grave 50 is the shears, another artefact that can be seen as a status indicator.

### Ceramic vessels

The vessels found in Grave 50 represent forms frequently met in Przeworsk culture assemblages during the Early Roman period and the beginnings of the Younger Roman period. Nevertheless, some references to the stylistic characteristic of the eastern range of that culture are evident. They can be seen in the presence of large vases (Fig. 8: 1, 2), including one provided with three knee-like handles (*cf.* Andrzejowski 2001, 80). A beaker on a high, hollow foot (Fig. 9: 1) finds no analogies in T. Liana's typology (1970), but such vessels, including examples with openwork feet, are known from some sites on the upper Vistula and on the upper and middle San (Madyda-Legutko *et al.* 2006, 397; Podgórska-Czopek and Czopek 1991, 107, fig. 15; Lasota-Kuś in print).

## CHRONOLOGY AND CONCLUDING REMARKS

In light of our findings, the analysed grave assemblage from Ostrów should be dated to the developed stage of the Early Roman period, i.e. phase B2b. The horse harness elements discovered in the grave are of importance to studies on funeral customs of the Przeworsk culture population. The small number of such artefacts previously known from sepulchral contexts suggested a marginal role of the horse in the funeral rite (*cf.* Kontny 2009, 98). The discovery of harness elements, spurs, and an exceptionally long sword indicates that Grave 50 held the burial of a mounted warrior. However, it is not easy to determine how the *Ringknaufschwert* found its way to the grave. It is widely known that the sale of weapons beyond the Roman Empire borders was formally prohibited (Dąbrowski and Kolendo 1967, 419-421). Perhaps the appearance of the sword in question should be linked with a period of turmoil in Central European *Barbaricum* pre-dating the Marcomannic Wars.

The presence of artefacts revealing connections with the Sarmatian milieu is a separate issue. As we know, Przeworsk-Sarmatian contacts in the upper Dniester basin are confirmed as early as the close of the Late Pre-Roman period (Kokowski 1999, 37-40). That these contacts continued in the Early Roman period is evidenced, among other things, by discoveries from south-eastern Poland (recently Kontny *et al.* 2019, 379-381). They became particularly intensive in the second half of the 2<sup>nd</sup> century and in the first three decades

of the 3<sup>rd</sup> century AD (Shchukin 1994, 486, 491; Dobrzańska 1999, 85, 86; Istvánovits and Kulcsár 2017, 258-289), which is also when the cemetery in Ostrów was in use. Apart from the horse harness elements discussed above, this direction of contacts is also suggested by a spearhead decorated with tamga symbols (signs typical of the Sarmatian culture) discovered in another grave in Ostrów.

As has already been demonstrated in the literature, connections with the so-called eastern range of the Przeworsk culture are also evident in the cemetery (Lasota-Kuś and Stempniak-Kusy 2019, 85; Andrzejowski 2020, 20, 21). In Grave 50, stylistic traits characteristic of that zone are revealed in particular by the three-handled vase used as the urn. The electrum pelta-shaped pendant decorated with granulation and filigree also deserves particular attention here. The artefact bears no traces of burning, and the place where it was discovered (top part of the grave) suggests the pendant was an offering rather than the personal property of the deceased.

Summing up, it is worth emphasising once again that the artefacts discovered in Grave 50 indicate that the warrior buried there enjoyed a unique status in his community.

## References

- Åberg N. 1919. *Ostpreussen in Völkerwanderungszeit*. Uppsala: A.-B. Akademiska Bokhandeln in Kommission.
- Ambroz K. 1989. *Khronologiya drevnosti Severnogo Kavkaza V-VII vv*. Moskva: Nauka.
- Andrzejowski J. 2001. Wschodnia strefa kultury przeworskiej – próba definicji. *Wiadomości Archeologiczne* 54, 59-87.
- Andrzejowski J. 2020. The eastern zone of the Przeworsk culture – and what it comprehends. *Acta Archaeologica Carpathica* 55, 9-38.
- Bantelmann N. 1971. *Hamfelde, Kreis Herzogtum Lauenburg. Ein Urnenfeld der römischen Kaiserzeit in Holstein (= Offa-Bücher 24)*. Neumünster: Wachholtz-Verlag.
- Biborski M. 1994. Typologie und Chronologie der Ringknaufschwerter. In H. Friesinger, A. Stuppner and J. Tejral (eds), *Markomannenkriege – Ursachen und Wirkungen. VI. Internationales Symposium "Grundprobleme der frühgeschichtlichen Entwicklung im nördlichen Mitteldonauebiet"* Wien 23.-26. November 1993 (= *Spisy Archeologického Ústavu AV ČR* 1). Brno: Archeologický Ústav Akademie Věd České Republiky, 85-97.
- Biborski M. 2020. The *Ringknaufschwert* type sword of a *beneficiarius*. In E. Papuci-Władyka (ed.), *Interdisciplinary Research of the Jagiellonian University in Nea Paphos Unesco World Heritage Site (2011-2015) – First Results (= Paphos Agora Project (PAP)* 1). Kraków: Historia Iagellonica, 411-417.
- Biborski M., Kaczanowski P., Kędzierski Z. and Stępiński J. 1997. Badania metaloznawcze mieczy z cmentarzyska ludności kultury przeworskiej w Krupicach, woj. Białystok. In J. Gurba and A. Kowowski (eds), *Kultura przeworska: (materiały z konferencji)* 3 (= *Lubelskie materiały archeologiczne* 8). Lublin: Wydawnictwo Uniwersytetu Marii Curie-Skłodowskiej, 227-241.

- Biborski M. and Kazior B. 1997. Badania sondażowe na cmentarzysku kultury przeworskiej z okresu wpływów rzymskich w Mokrej, województwo częstochowskie. *Badania archeologiczne na Górnym Śląsku i ziemiach pogranicznych w 1994 roku*, 113-117.
- Błażejewski A. 2007. *Kultura przeworska a reńsko-wezerska strefa kulturowa. Studia Archeologiczne 39* (= *Acta Universitatis Wratislaviensis* 2939). Wrocław: Wydawnictwo Uniwersytetu Wrocławskiego.
- Bochnak T. and Opielowska-Nowak Z. in print. „Habent sua fata situlae” – brązowe naczynie z Przemysła-Kazanowa.
- Bulas J., Kotowicz P. N. and Okońska M. 2019. A new Roman Period burial ground of the Przeworsk culture from Pakoszówka (the Upper San River basin). *Acta Archaeologica Carpathica* 54, 91-106.
- Ciesielski M. 2008. Sprawozdanie z prac archeologicznych na cmentarzysku kultury przeworskiej w Zapowiedni (stan. 5), gm. Pyzdry, woj. Wielkopolskie – pierwszy sezon badań. In J. Skowron and M. Olędzki (eds), *Kultura przeworska. Odkrycia – interpretacje – hipotezy 2*. Łódź: Uniwersytet Łódzki. Wydział Studiów Międzynarodowych i Politologicznych. Instytut Studiów Międzynarodowych, 259-298.
- Dąbrowski K. and Kolendo J. 1967. Z badań nad mieczami rzymskimi w Europie środkowej i północnej. *Archeologia Polski* 12/2, 383-426.
- Dinnyés I. 1991. A hévizgyörki szarmata sírok. *Studia Comitatus* 22, 145-202.
- Droberjar E. 1999. Od plaňanských pohárů k vinařické skupině. Kulturní a chronologické vztahy na území Čech v době římské a v časně době stěhování národů. *Sborník Národního Muzea v Praze* 53, 1-57.
- Dobrzańska H. 1999. Sarmaci na ziemiach Polski – mit czy rzeczywistość? *Archeologia Polski* 44 (1-2), 75-91.
- Dulkiewicz A. 2009. Szpile kościane i rogowe kultury przeworskiej na terenie Polski: typologia, chronologia i rozmieszczenie. *Folia Praehistorica Posnaniensia* 15, 209-235.
- Eggers H. J. 1955. Zur absoluten Chronologie der römischen Kaiserzeit im Freien Germanien. *Jahrbuch des Römisch-Germanischen Zentralmuseums Mainz* 2, 196-244.
- Engelhardt C. 1869. Vimose Fundet. *Fynske Mosefund* 2. Kjøbenhavn: Gad.
- Geisler H. 1974. Das germanische Urnengräberfeld bei Kemnitz, Kr. Potsdam-Land. Teil I. Katalog (= *Veröffentlichungen des Museums für Ur- und Frühgeschichte Potsdam* 8). Berlin: Deutscher Verlag der Wissenschaften.
- Ginalski J. 1991. Ostrogi kabłąkowe kultury przeworskiej. Klasyfikacja typologiczna. *Przegląd Archeologiczny* 38, 53-84.
- Godłowski K. 1977. Materiały do poznania kultury przeworskiej na Górnym Śląsku (część II). *Materiały Starożytne i Wczesnośredniowieczne* 4, 7-234.
- Godłowski K. 1991. Jakuszowice – a multi-period settlement in southern Poland. *Antiquity* 65/248, 662-675.
- Godłowski K. 1992. Zmiany w uzbrojeniu ludności kultury przeworskiej w okresie wpływów rzymskich. In M. Głosek, M. Mielczarek, W. Świątosławski and K. Walenta (eds), *Arma et Ollae. Studia*

- dedykowane Profesorowi Andrzejowi Nadolskiemu w 70 rocznicę urodzin i 45 rocznicę pracy naukowej. Sesja naukowa, Łódź, 7-8 maja 1992 r.* Łódź: Stowarzyszenie Naukowe Archeologów Polskich Oddział w Łodzi, 71-88.
- Godłowski K. and Szadkowska L. 1972. Cmentarzysko z okresu rzymskiego w Tarnowie, powiat Opole. *Opolski Rocznik Muzealny* 5, 5-246.
- Grumeza L. 2016. Sarmatian Personal Ornaments from the South-Eastern Part of the Great Hungarian Plain During the 1<sup>st</sup>-3<sup>rd</sup> Centuries CE: Imports and Local Production. In V. Cojocar and A. Rubel (eds), *Mobility in Research on the Black Sea Region. The Proceedings of the International Symposium organized by the Iași Branch of the Romanian Academy, in collaboration with German Cultural Centre of Iași (July 5-10, 2015), supported by the Romanian National Authority for Scientific Research, CNCS – UEFISCDI, project number PN-II-ID-PCE-2011-3-0054 and PN-II-PCE-2012-4-0490.* Cluj-Napoca: Mega Publishing House, 439-482.
- Guguev V. K. and Bezuglov S. I. 1990. Vsadnicheskoe pogrebenie pervykh vekov nashey ery iz kurganogo nekropolia Kobyakova gorodishcha na Donu. *Sovetskaya Arkheologiya* 2, 164-175.
- Horbacz T. J. and Ołędzki M. 1992. Inkrustowane miecze rzymskie z Barbaricum i obszarów przylimesowych Imperium Romanum: wybrane zagadnienia. *Acta Universitatis Lodziensis. Folia Archaeologica* 17, 91-129.
- Hundt H.-J. 1953. Ein tauschiertes römisches Ringknaufschwert aus Straubing (Sorviodurum). *Festschrift des Römisch-Germanischen Zentralmuseums in Mainz* 3, 109-118.
- Istvánovits E. and Kulcsár V. 2017. *Sarmatians – History and Archaeology of a Forgotten People* (= *Monographien des Römisch-Germanischen Zentralmuseums* 123). Mainz: Verlag des Römisch-Germanischen Zentralmuseums.
- Istvánovits E. and Kulcsár V. 2003. Some traces of Sarmatian-Germanic contacts in the Great Hungarian Plain. In C. von Carnap-Bornheim (ed.), *Kontakt – Kooperation – Konflikt. Germanen und Sarmaten zwischen dem 1. und dem 4. Jahrhundert nach Christus. Internationales Kolloquium des Vorgeschichtlichen Seminars der Philipps-Universität Marburg, 12.-16. Februar 1998* (= *Schriften des Archäologischen Landesmuseums* 1). Neumünster: Wachholtz Verlag, 227-238.
- Jahn M. 1916. *Die Bewaffnung der Germanen in der älteren Eisenzeit, etwa von 700 v. Chr. Bis 200 n. Chr.* (= *Mannus-Bibliothek* 16). Würzburg: Kabitzsch.
- Jamka R. 1963. *Materiały kultury przeworskiej z Leonowa, stanowisko II, pow. Łódź* (= *Zeszyty Naukowe Uniwersytetu Jagiellońskiego* 73, *Prace Archeologiczne* 5), 59-75.
- Jaskanis 2005. *Krupice. Ein Gräberfeld der Przeworsk- und Wielbark-Kultur in Ostpolen.* (= *Monumenta Archaeologica Barbarica* 10). Warszawa: Fundacja Przyjaciół Instytutu Archeologii Uniwersytetu Warszawskiego, Stowarzyszenie Naukowe Archeologów Polskich Oddział w Warszawie and Państwowe Muzeum Archeologiczne w Warszawie.
- Kaczanowski P. 1992. *Importy broni rzymskiej na obszarze europejskiego Barbaricum.* Rozprawy Habilitacyjne 244. Kraków: Uniwersytet Jagielloński.
- Kaczanowski P. 1995. *Klasyfikacja grotów broni drzewcowej kultury przeworskiej z okresu rzymskiego* (= *Klasyfikacje zabytków archeologicznych* 1). Kraków: Instytut Archeologii i Etnologii Polskiej Akademii Nauk and Uniwersytet Jagielloński.



- Kaczanowski P. and Zaborowski J. 1988. Bemerkungen über die Bewaffnung der Bevölkerung der Wielbark-Kultur. In: J. Gurba and A. Kokowski (eds), *Kultura wielbarska w młodszym okresie rzymskim: (materiały z konferencji)* 1. Lublin: Wydawnictwo Uniwersytetu Marii Curie-Skłodowskiej, 221-239.
- Kargopoltsev S. I. and Bajan I. A. 1993. K voprosu ob evoliutsii trekhrogikh peltovidnykh lunnits v Evrope (III-VI vv.). *Petersburg Archaeological Herald* 7, 113-124.
- Keller H.-J. 1966. Zu den römischen Ringknaufschwertern und Dosenortbändern in Bayern. *Jahrbuch des Römisch-Germanischen Zentralmuseums Mainz* 13, 190-201.
- Khrapunov I. N. 2006. Sklep III v. n.e. iz mogilnika Neyzats. *Journal of Historical, Philological and Cultural Studies*. Moskwa-Magnitogorsk: Russian Academy of Sciences and Institute of Archaeology, 104-118.
- Knaack A. 1978. Beobachtungen an Scherenbeigabe in Gräbern des elbgermanischen Siedlungsgebietes während der römischen Kaiserzeit. *Ethnographisch-Archäologische Zeitschrift* 19/1, 15-50.
- Kokowski A. 1999. Strefy kulturowe w młodszym okresie przedrzymskim i w okresie rzymskim na łuku Karpat. Część I – od młodszego okresu przedrzymskiego do młodszego okresu rzymskiego. In S. Czopek and A. Kokowski (eds), *Na granicach antycznego świata. Sytuacja kulturowa w południowo-wschodniej Polsce i regionach sąsiednich w młodszym okresie przedrzymskim i okresie rzymskim*. Rzeszów: Muzeum Okręgowe w Rzeszowie, 25-44.
- Kontny B. 2009. Horse and its use in the Przeworsk culture in the light of archaeological evidence. *Archaeologia Baltica* 11, 92-114.
- Kontny B. 2017. Smok (?) z Łabapy. Ze studiów nad ornamentowanymi grotami z okresu wpływów rzymskich. In J. Andrzejowski, C. v. Carnap-Bornheim, A. Cieśliński and B. Kontny (eds), *Orbis Barbarorum. Studia ad archaeologiam germanorum et baltorum temporibus imperii romani pertinentia Adalberto Nowakowski dedicata (= Monumenta Archeologica Barbarica. Series Gemina 6)*. Warszawa-Schleswig: Instytut Archeologii Uniwersytetu Warszawskiego, Zentrum für Baltische und Skandinavische Archäologie, Fundacja Monumenta Archaeologica Barbarica, 191-207.
- Kontny B. 2019. *Archeologia wojny. Ze studiów nad uzbrojeniem barbarzyńskiej Europy okresów wpływów rzymskich i wędrówek ludów*. Oświęcim: Wydawnictwo Napoleon V.
- Kontny B., Grabarek A. and Jaskulska E. 2019. A unique Sarmatian-type arrowhead from feature 109 from a Przeworsk culture necropolis in Podlesie, Oleśnica district, Świętokrzyskie voivodeship. *Sprawozdania Archeologiczne* 71, 359-385.
- Kropotkin V. V. 1978. Cherniakhovskaya kultura i Severnoe Prichernomore. In V. V. Kropotkin, B. G. Peters and G. N. Matjusin (eds), *Problemy sovetskoy arkheologii*. Moskwa: Nauka, 147-163.
- Kurpiewski A. and Lewandowska J. 2013. Sadłowo – nowa karta w badaniach osadnictwa kultury wielbarskiej na ziemi dobrzyńskiej. *Wiadomości Archeologiczne* 54, 172-190.
- Lasota A. and Stempniak S. 2015. Nowo odkryte cmentarzysko z wczesnego i młodszego okresu wpływów rzymskich w Ostrowie, stan. 21, gm. Przemyśl, woj. podkarpackie. In: L. Tyszler and E. Drobnerjar (eds), *Barbari superiores et inferiores. Archeologia barbarzyńców 2014. Procesy integracji środkowoeuropejskiego Barbaricum Polska – Czechy – Morawy – Słowacja. Barbari superiores*

- et inferiores. Integration processes of the Central European Barbaricum. Poland – Bohemia – Moravia – Slovakia.* Łódź, Wieluń: Instytut Archeologii Uniwersytetu Łódzkiego, Muzeum Ziemi Wieluńskiej w Wieluniu, Stowarzyszenie Naukowe Archeologów Polskich Oddział w Łodzi, 225-233.
- Lasota-Kuś A. 2018. A cinerary urn from site 21 in Ostrów, Przemyśl District. A contribution to studies on the meaning and role of ornamentation of Early Roman Period ceramic vessels in the Przeworsk culture. *Sprawozdania Archeologiczne* 70, 153-171.
- Lasota-Kuś A. w druku. *Zróżnicowanie typologiczno-chronologiczne i kulturowe ceramiki z wczesnego okresu rzymskiego z terenu południowo-zachodniej małopolski.* Kraków: Instytut Archeologii i Etnologii Polskiej Akademii Nauk.
- Lasota-Kuś A. and Madyda-Legutko R. 2018. Złote „wieszadelka” z okresu rzymskiego z cmentarzyska w Gaci, pow. przeworski. In B. Niezabitowska-Wiśniewska, P. Łuczkiwicz, S. Sadowski, M. Stasiak-Cyran and M. Erdrich (eds), *Studia Barbarica. Profesorowi Andrzejowi Kokowskiemu w 65. rocznicę urodzin. For Professor Andrzej Kokowski on his 65<sup>th</sup> birthday* 1. Lublin: Wydawnictwo Uniwersytetu Marii Curie-Skłodowskiej, 296-306.
- Lasota-Kuś A. and Stempniak-Kusy S. 2019. Cemetery in Ostrów, site 21 as the example of multidirectional contacts of the Przeworsk culture – people living in the central part of the San River basin in the Early and Younger Roman Period. *Acta Archaeologica Carpathica* 54, 77-89.
- Lau N. 2014. Die Pferdegeschirre. Germanische Zaumzeuge und Sattelgeschirre als Zeugnisse kriegerischer Reiterei im mittel- und nordeuropäischen Barbaricum (= *Das Thorsberg Moor* 1). Schleswig: Verein zur Förderung des Archäologischen Landesmuseums e. V.
- Liana T. 1970. Chronologia względna kultury przeworskiej we wczesnym okresie rzymskim. *Wiadomości Archeologiczne* 35, 429-491.
- Madyda-Legutko R. 1998. Importy rzymskie w polskich Karpatach. In J. Kolendo (ed.), *Nowe znaleziska importów rzymskich z ziem Polski 1* (= *Corpus der römischen Funde im europäischen Barbaricum – Polen. Supplement – Band 1. Neue Funde römischen Importe aus Polen 1*). Warszawa: Instytut Archeologii Uniwersytetu Warszawskiego, 29-39.
- Madyda-Legutko R., Rodzińska-Nowak J. and Zagórska-Telega J. 2005. Uwagi na temat reguł wyposażania zmarłych w kulturze przeworskiej w okresie rzymskim. In W. Dzieduszycki and J. Wrześciński (eds), *Do ut des – dar, pochówek, tradycja* (= *Funeralia Lednickie. Spotkanie 7*). Poznań: Stowarzyszenie Naukowe Archeologów Polskich Oddział w Poznaniu, 181-188.
- Madyda-Legutko R., Rodzińska-Nowak J. and Zagórska-Telega J. 2006. Prusiek, pow. sanocki, stan. 25. Pierwsze cmentarzysko ludności kultury przeworskiej w polskich Karpatach. *Wiadomości Archeologiczne* 58, 394-400.
- Madyda-Legutko R., Rodzińska-Nowak J. and Zagórska-Telega J. 2007. Wyniki dalszych badań na cmentarzysku kultury przeworskiej w Prusieku stan. 25, pow. Sanok. *Rocznik Przemyski* 43/2, 61-69.
- Madyda-Legutko R., Rodzińska-Nowak J. and Zagórska-Telega J. 2010. Złote wisioriki z cmentarzyska ludności kultury przeworskiej w Prusieku, stan. 25, gm. Sanok. In A. Urbaniak, R. Prochowicz, I. Jakubczyk, M. Levada and J. Schuster (eds), *Terra Barbarica. Studia ofiarowane Magdalenie Mączyńskiej w 65. rocznicę urodzin* (= *Monumenta Archaeologica Barbarica, Series Gemina* 2).

- Łódź, Warszawa: Instytut Archeologii Uniwersytetu Łódzkiego, Fundacja Monumenta Archaeologica Barbarica, 387-395.
- Madyda-Legutko R., Rodzińska-Nowak J. and Zagórska-Telega J. 2011a. Opatów Fpl. 1. *Ein Gräberfeld der Przeworsk-Kultur im nordwestlichen Klempolen. Katalog* (= *Monumenta Archaeologica Barbarica* 15/1). Warszawa, Kraków: Fundacja Monumenta Archaeologica Barbarica, Instytut Archeologii Uniwersytetu Jagiellońskiego, Państwowe Muzeum Archeologiczne w Warszawie.
- Madyda-Legutko R., Rodzińska-Nowak J. and Zagórska-Telega J. 2011b. Opatów Fpl. 1. *Ein Gräberfeld der Przeworsk-Kultur im nordwestlichen Klempolen. Tafeln* (= *Monumenta Archaeologica Barbarica* 15/2). Warszawa – Kraków: Fundacja Monumenta Archaeologica Barbarica, Instytut Archeologii Uniwersytetu Jagiellońskiego, Państwowe Muzeum Archeologiczne w Warszawie.
- Mączyńska M. and Jagusiak M. 2002. Cmentarzysko z okresu rzymskiego w Czarnocinie, pow. Piotrków Trybunalski, stanowisko 1. In J. Andrzejowski, R. Prochowicz and A. Żórawska (eds), *Varia Barbarica. Zenonowi Woźniak ab amicis dicata* (= *Monumenta Archaeologica Barbarica. Series Gemina* 1). Warszawa, Lublin: Fundacja Przyjaciół Instytutu Archeologii Uniwersytetu Warszawskiego, Instytut Archeologii Uniwersytetu Marii Curie-Skłodowskiej w Lublinie, Państwowe Muzeum Archeologiczne w Warszawie, 353-374.
- Mączyński P. and Polit B. 2016. Wytwory krzemienne z cmentarzyska z późnej starożytności Nejcz na Krymie. *Wiadomości Archeologiczne* 67, 175-193.
- Meyer E. 1971. Die germanischen Bodenfunde der spätrömischen Kaiserzeit und der frühen Völkerwanderungszeit in Sachsen. I. Katalog (= *Arbeits- und Forschungsberichte zur Sächsischen Bodendenkmalpflege* 9). Berlin: VEB Deutscher Verlag der Wissenschaften.
- Miks Ch. 2017. Zum Wandel der römischen Schwertausrüstung im 2. Jh. n. Chr. und seinem Stand zur Zeit der Markomannenkriege. *Študijné Zvesti Archeologického Ústavu SAV* 62, 113-136.
- Natuniewicz-Sekuła M. 2020. *Złotnictwo społeczności kultury wielbarskiej za szczególnym uwzględnieniem wybranych zabytków z cmentarzyska w Weklicach*. Warszawa: Instytut Archeologii i Etnologii Polskiej Akademii Nauk.
- Ørsnes M. 1993. Zaumzeugfunde des 1.-8. Jahrh. Nach Chr. In Mittel- und Nordeuropa. *Acta Archaeologica* 64, 183-292.
- Podgórska-Czopek J. and Czopek S 1991. Materiały z osady kultury łużyckiej (grupy tarnobrzesckiej) i kultury przeworskiej ze stanowiska 1 w Tarnobrzegu-Zakrzowie. *Materiały i Sprawozdania Rzeszowskiego Ośrodka Archeologicznego za lata 1980-1984*, 71-114.
- Peška J. 2002. Das Grab. In J. Peška and Tejral J. 2002. *Das germanische Königsgrab von Mušov in Mähren*. Teil 1. Mainz: Verlag des Römisch-Germanischen Zentralmuseums, 3-72.
- Pinar J., Padró E. and Juárez T. 2007. New Data on the Role of Mediterranean Metalworkshops in Barbarian Aristocratic Culture. Concerning Two Ancient, Scarcely Known Finds from 5<sup>th</sup>-century Hispania. In E. Droberjar and O. Chvojka (eds), *Archeologie barbarů 2006*. České Budějovice: Jihočeské Muzeum, 579-586.
- Raddatz K. 1961. Ringknaufschwerter aus germanischen Kriegergräbern. *Offa* 17/18, 25-55.
- Rajtár J., Hüssen C.-M., Iván R. Kováčsová L and Ölvecký R. 2019. Das germanische Brandgräberfeld in Selule. In M. Karwowski, B. Komoróczy and P. Trebsche (eds), *Auf den Spuren der Barbaren*

- *Archäologisch, Historisch, Numismatisch (Archäologie der Barbaren 2015)* (= *Spisy Archeologického Ústavu AV ČR Brno* 60). Brno: Archäologisches Institut der Akademie der Wissenschaften der Tschechischen Republik, 131-135.
- Rákoš J. 2019. Przeworsk culture cemetery at Rankovce (Eastern Slovakia). Preliminary report. *Acta Archaeologica Carpathica* 54, 215-226.
- Rodzińska-Nowak J., Bulas J., Kasiński M. and Okońska M. 2021. A Pelta-shaped Golden Pendant from the Przeworsk Culture Settlement in Rzemienowice, Site 1, Kazimierza Wielka Country. In R. Ciolek and R. Chowaniec (eds), *Aleksandria. Studies on Items, Ideas and History Dedicated to Professor Aleksander Bursche on the Occasion of his 65<sup>th</sup> Birthday*. Wiesbaden: Harrassowitz Verlag, 347-351.
- Rudnicki M. 2009. Uwagi na temat niektórych form zawieszek w grupie olsztyńskiej. In A. Bitner-Wróblewska and G. Iwanowska (eds), *Baltowie i ich sąsiedzi. Marian Kaczyński in memoriam* (= *Seminarium Bałtyjskie* 2). Warszawa: Państwowe Muzeum Archeologiczne w Warszawie, 421-436.
- Sadowski S. 2004. Miecz z grobu 8 z cmentarzyska Zvenyhorod – „Hoeva Hora“ na Ukrainie. Przyczynek do badań nad rozprzestrzenieniem się mieczy z pierścieniowatym zakończeniem rękojeści. In A. Kokowski (ed.), *Sarmaci i Germanie* (= *Studia Sarmatica* 1). Lublin: Wydawnictwo Uniwersytetu Marii Curie-Skłodowskiej, 265-288.
- Schranil J. 1928. *Die Vorgeschichte Böhmens und Mährens*. Berlin and Leipzig: Walter de Gruyter.
- Shchukin M. 1994. Shields, swords and spears as evidence of Germanic-Sarmatian contacts and Barbarian-Roman relations. In C. von Carnap-Bornheim (ed.), *Beiträge zu römischer und barbarischer Bewaffnung in den ersten vier nachchristlichen Jahrhunderten. Akten des 2. Internationalen Kolloquiums in Marburg a. d. Lahn, 20. bis 24. Februar 1994* (= *Veröffentlichung des Vorgeschichtlichen Seminars Marburg* 8). Lublin, Marburg: Wydawnictwo Uniwersytetu Marii Curie-Skłodowskiej, 485-495.
- Simonenko A. V. 2000. Bewaffnung und Kriegswesen der Sarmaten und späten Skythen im nördlichen Schwarzmeergebiet. *Eurasia Antiqua* 7, 187-327.
- Skóra K. 2008. Z czym wędrowano w zaświaty? O niemilitarnym wyposażeniu grobowym wojowników „wielbarskich”. In W. Świętosławski (ed.), *Nie tylko broń. Niemilitarne wyposażenie wojowników w starożytności i średniowieczu* (= *Acta Archaeologica Lodziensia* 54). Łódź: Łódzkie Towarzystwo Naukowe, 7-27.
- Shukin M. B. and Sherbakova T. A. 1986. K khronologii mogilnika Dancheny. In: I. A. Rafalovich (ed.), *Dancheny. Mogilnik Cherniakhovskoy kultury III–IV vv. n.č.* Kishinev, 177–212.
- Tempelmann-Mączyńska M. 1986. Der Goldfund aus dem 5. Jahrhundert n. Chr. aus Granana-Albaicin und seine Beziehungen zu Mittel- und Osteuropa. *Madriider Mitteilungen* 27, 375-388.
- Thomas S. 1960. Studien zu den germanischen Kämmen der römischen Kaiserzeit. *Arbeits- und Forschungsberichte zur sächsischen Bodendenkmalpflege* 8, 54-215.
- Werner J. 1988. ‘Dančeny and Brangstrup. Untersuchungen zur Černjachov-Kultur zwischen Sereth und Dnestr und zu den ‘Reichtumszentrum’ auf Fünen. *Bonner Jahrbücher* 188, 241-286.

- Wilbers-Rost S. 1994. *Pferdegeschirr der römischen Kaiserzeit in der Germania libera: zur Entstehung, Entwicklung und Ausbreitung des „Zaumzeugs mit Zügelketten“* (= *Veröffentlichungen der Urgeschichtlichen Sammlungen des Landesmuseums zu Hannover* 44). Hannover: Niedersächsisches Landesmuseum Hannover.
- Vaday A. H. 1986. Beitrag zum Fund von Vizesd-Puszta. *Folia Archaeologica* 37, 197-223.
- Voroniátov S. 2012. Sarmatische Elemente im Inventar des Königsgrabs von Mušov in Südmähren. *Eurasia Antiqua. Zeitschrift für Archäologie Eurasiens* 18, 185-195.
- Zieling N. 1989. Studien zu germanischen Schilden der Spätlatène- und der römischen Kaiserzeit im freien Germanien (= *British Archaeological Research. International Series* 505). Oxford: Archaeopress.

