

Iryna Kozyr<sup>1</sup>, Kyrylo Panchenko<sup>2</sup>, Oleksandr Chorny<sup>3</sup>

## FUNERAL RITE IN THE MOUND OF SCYTHIAN TIME NEAR VASYNE

### ABSTRACT

Kozyr I., Panchenko K., Chorny O. 2023. Funeral rite in the mound of Scythian time near Vasyne. *Sprawozdania Archeologiczne* 75/1, 335-356.

The article is devoted to an analysis of the funeral rite from the mound near the village of Vasyne in Kirovohrad region. The site is located on the border of the Dnipro right-bank forest-steppe and steppe. The main Scythian burial was deposited in a wooden chamber on the ancient ground surface. A complex wooden burial structure of oak timbers constructed over it was partially burnt, but was well preserved. The remains of artefacts found in the burial site, including fragments of ancient amphoras, among them plump-throated Chios, thin-walled antique black-figured kylix, fragments of ceramic vessels, and animal bones. Undoubtedly, the most interesting find was a stone anthropomorphic stele of grey granite. The complex dates to the first quarter of the 5<sup>th</sup> century BC.

Keywords: barrow, Scythian time, mound, anthropomorphic stele, trizna ritual

Received: 12.09.2022; Revised: 22.05.2023; Accepted: 20.09.2023

1 Volodymyr Vynnychenko Central Ukrainian State University, Shevchenka Str. 1, 25006 Kropyvnytskyi, Ukraine; kozyrir@gmail.com; ORCID: 0000-0002-0368-8758

2 Volodymyr Vynnychenko Central Ukrainian State University, Shevchenka Str. 1, 25006 Kropyvnytskyi, Ukraine; pankir90@gmail.com; ORCID: 0000-0002-3988-5294

3 Volodymyr Vynnychenko Central Ukrainian State University, Shevchenka Str. 1, 25006 Kropyvnytskyi, Ukraine; komandarmus12@gmail.com; ORCID: 0000-0001-5169-3554

The barrow cemetery near the village of Vasyne in Kirovohrad region is located in the upper reaches of the river Beshka (Kozyr *et al.* 2019, 300), a right tributary of the upper reaches of the Inhulets river (Fig. 1) (Kryvulchenko 2011, 146, 245). The excavated barrow discussed here is labelled No. 33 and was part of Group 8 of mounds. In the spring of 2017, during deep ploughing, the upper part of a Scythian stone anthropomorphic stele with relief images and a fresh fracture was discovered in the barrow mound. On the surface of the stele, especially on its front part, the damage caused by the plough is clearly visible. The site was explored by an archaeological expedition of the Central Ukrainian State University in August – September 2017. The material from these excavations was published by the authors of this article (Kozyr *et al.* 2019).

This article is devoted to the analysis of the funeral rite performed during the construction of the mound. The height of the barrow is 1.7 m above the level of the modern surface, the diameter is 48 m. The surface of the barrow has been ploughed for a long time, its mound is eroded, and has a segmented shape. At the top of the ploughed-out earthwork, at the site of the discovery of the fragment of the stone stele, there were the remains of burnt and rotten wood visible on the surface.

The barrow had previously been significantly damaged during World War II. During excavations in the northern sector of the barrow, significant traces of destruction were



Fig. 1. Barrow No. 33 near the village of Vasyne on the map of Ukraine



Fig. 2. Vasyne Barrow 33 during excavation

found: a dugout, trenches, areas of mixed soil from shellings. An artillery shell, grenade, bullet casings, remnants of a portable radio station and iron objects, wire, metal dishes, pieces of roofing material, remnants of wooden boxes and other similar items were found. Also, at a depth of 0.2 m from the surface of the barrow the lower part of a destroyed skeleton was found. The condition of the bones allows us to attribute it to the period of World War II.

The main Scythian burial was laid on the ancient ground surface, which had carefully been cleaned of turf. A complex wooden burial structure constructed of oak timbers was well preserved, but partially burnt, which allows for a fairly complete reconstruction of its architecture and appearance. In the centre of the funerary structure was a square wooden tomb, oriented to the cardinal points with a slight deviation. Its dimensions at its base were  $5.5 \times 5.5$  m (Figs 4-6). Due to the destruction of the supporting posts, the walls of the tomb in the upper part were deformed and bent inwards. The size of the tomb was 5.25-5.4 m.

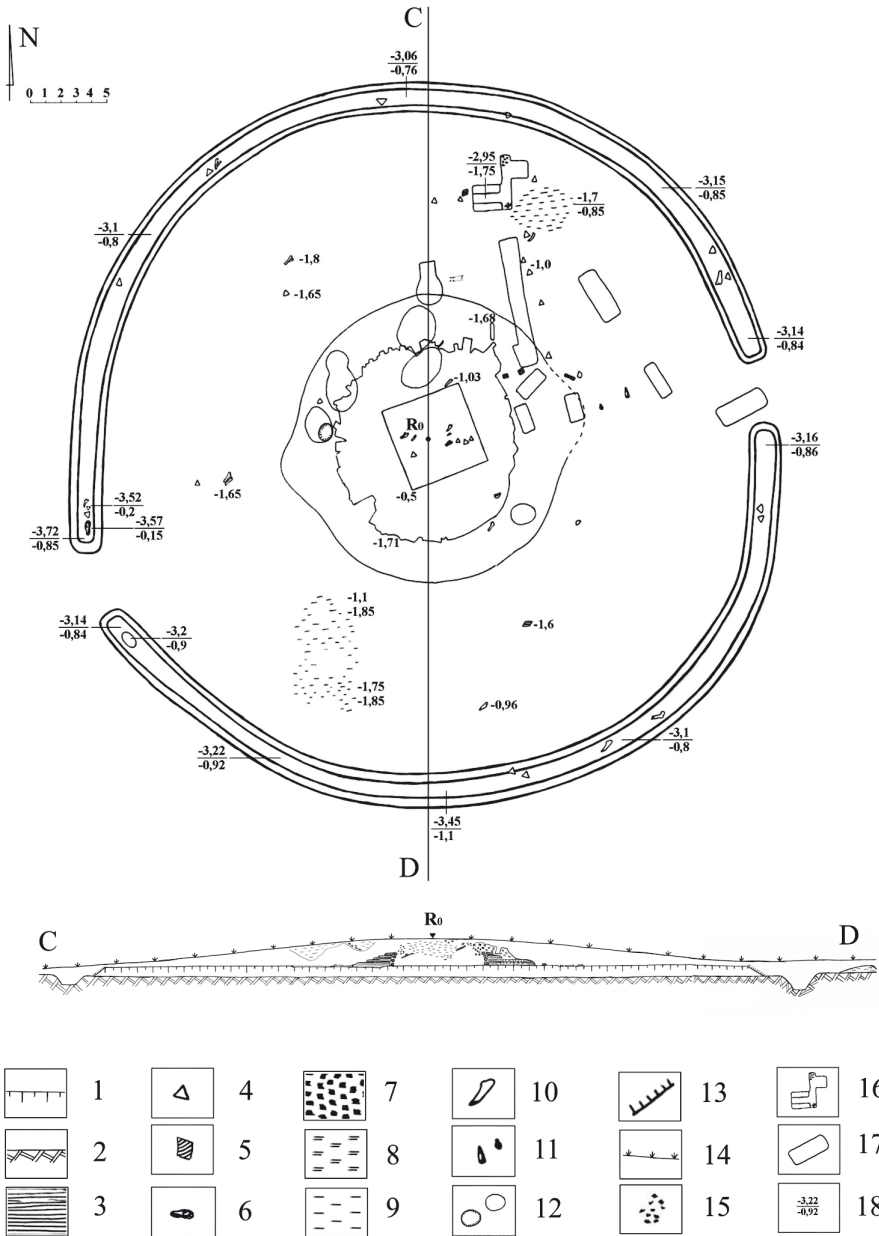

**Fig. 3.** Plan (1) and profile (2) of Vasyne Barrow 33: 1 – ancient ground surface; 2 – natural ground; 3 – scorched wood; 4 – amphora fragments; 5 – fragments of pottery vessels; 6 – horse skull; 7 – burnt wood; 8 – fired clay; 9 – unfired clay; 10 – animal bones; 11 – ammunition from World War II; 12 – pits from explosions during World War II; 13 – edges of the mound; 14 – modern ground surface; 15 – charcoal; 16 – a dugout from World War II; 17 – trench from World War II; 18 – depth of the ditch from R0/upper surface of natural loam

The frame of the tomb was built of wooden beams of a square section 0.15-0.2 m thick. The beams were made of logs by trimming four faces to ensure a tight fit. On many beams, the corners between the faces remained rough and retained a rounded shape. The load-bearing structures were ten wooden posts dug vertically in the centre, corners and along the walls of the tomb. These were rounded in cross section had a diameter of 17 to 28 cm, and were dug into the ground 0.5-1 m from the level of the ancient surface. The state of preservation of the supporting pillars was different: the central pillar and the pillars located by the southern and northern walls of the frame had collapsed completely to the bottom of the tomb, and the others survived to a height of 0.16-0.73 m.

The walls of the tomb were brought up vertically close to the supporting pillars, at the corners they were laid in a joint. The western wall has been preserved to a height of 1.3 m (five full rows of beams), the southern and eastern – 1 m, the northern – 0.9 m (four rows of beams each). The ceiling had not been fully preserved, but its remains can be traced in the stratigraphy of the filling of the tomb and in some places on its walls. Fragments of

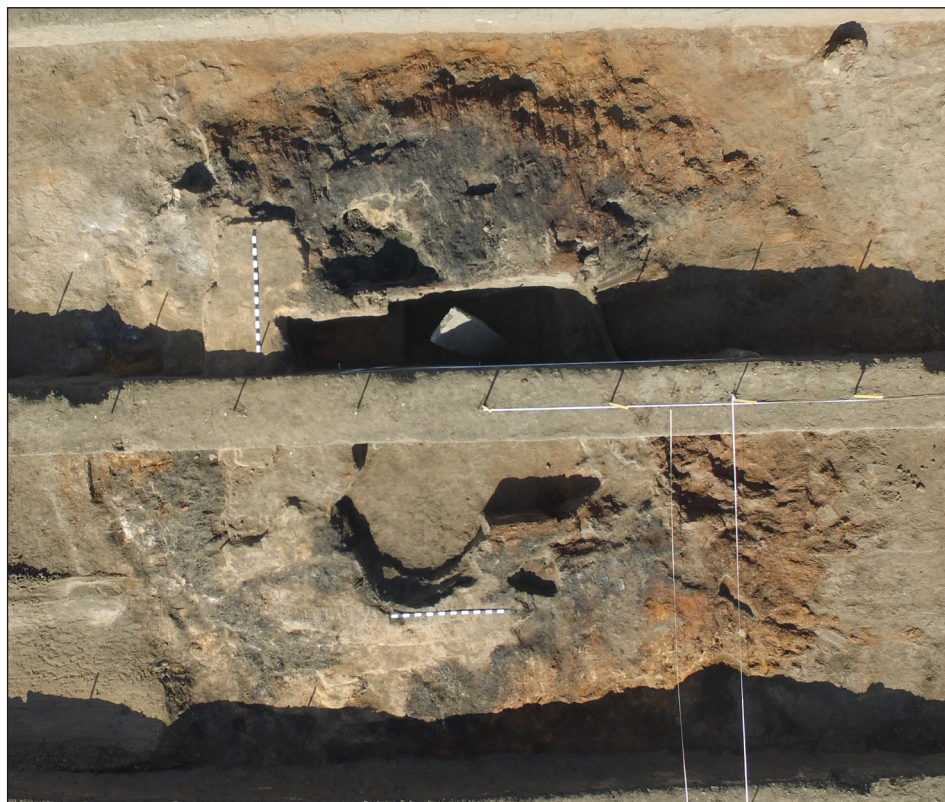

Fig. 4. Remains of a wooden burial structure in Vasyne Barrow 33

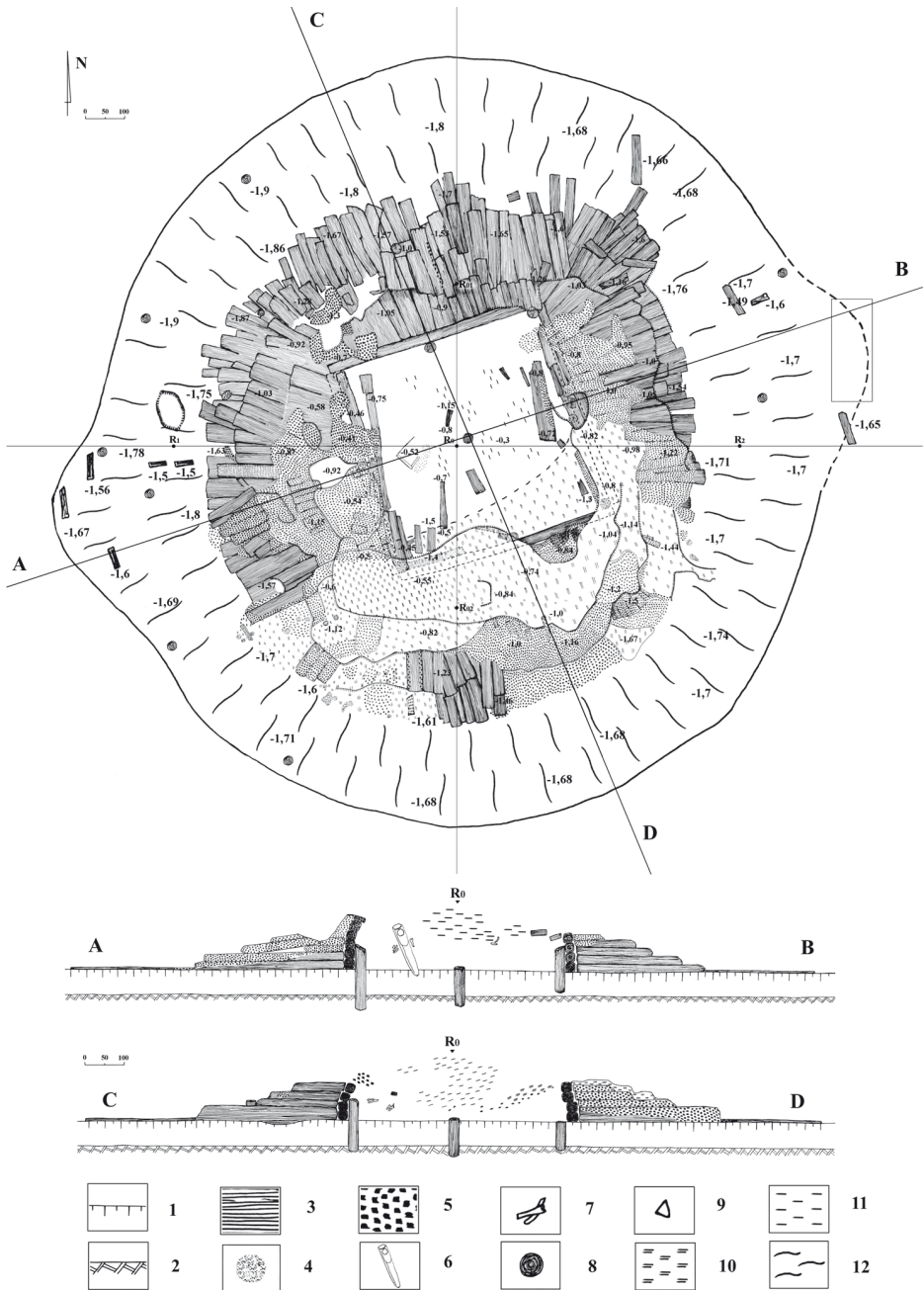

Fig. 5. Plan (1) and profiles (2, 3) of the tomb in Vasyne Barrow 33: 1 – ancient ground surface 2 – natural ground; 3 – scorched wood; 4 – ash; 5 – burnt wood; 6 – stone anthropomorphic stele; 7 – animal bones; 8 – wooden post; 9 – ceramics; 10 – fired clay; 11 – unfired clay; 12 – wooden decking

beams with a width of 0.2-0.3 m, a thickness of 0.12-0.15 and fragments of cross beams were recorded. Judging by their placement in the filling of the tomb, the cross beams (at least three) were laid west to east on posts, and they supported a continuous flat overlap of planed rectangular beams running from north to south.

Around the square tomb, close to its walls, a complex cone-shaped wooden structure was erected from several horizontal layers of logs. They were placed according to a clear system: perpendicular to the walls of the tomb and radially at its corners (Figs 4-6). The lower tier is made of solid tree trunks, 30-40 cm in diameter and 3.2-4 m long, on which the remains of bark and, in some places, stumps of branches have been preserved in many places. Each subsequent tier was made of shorter trunks or logs of smaller diameter laid in a checkerboard pattern, so that the layers of wood narrowed stepwise to the top. Together with the adjacent construction of logs and their segments, the flat ceiling of the tomb, formed a kind of “pyramid” in the core of the mound with a total diameter of 12.5-13 m (Figs 2 and 4). The height of the preserved “pyramid” was: 1.3-1.4 m in the western sector, on the, south and east it was 1 m, and on the north it was 0.9 m. All these stacks of wood were stacked very tightly, and in the upper part of the structure split logs were used to fill the volume. Vertical support columns were dug in some places to strengthen the walls, or transverse segments of logs were laid. At the same time, in the western and south-eastern profile of the “pyramid” at the level of the second - third tier of logs, artificial cavities were

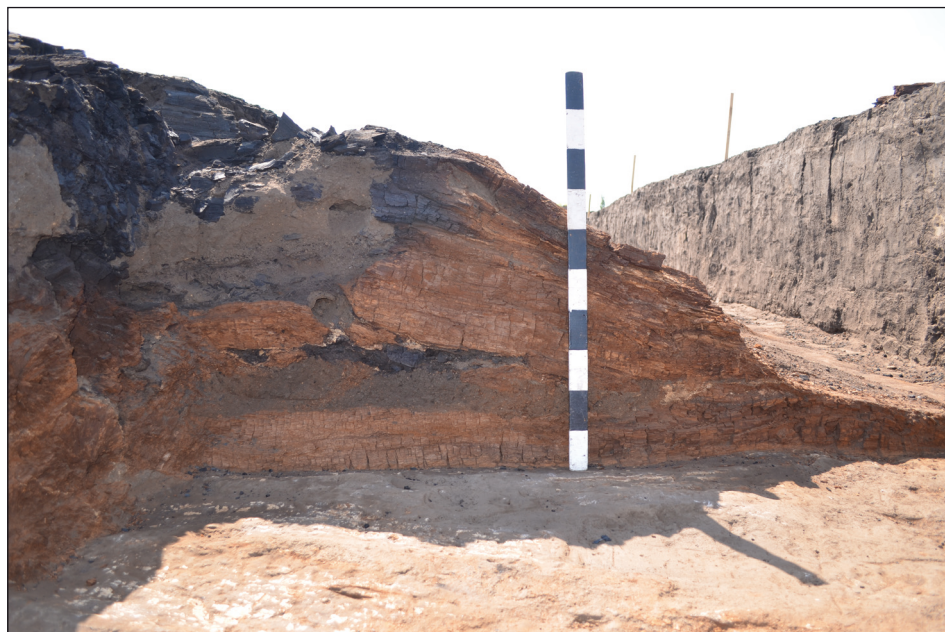

Fig. 6. Profile of the wooden “pyramid” in the core of the mound. Western sector

recorded, formed by a special method of construction, when the lower tier logs were superimposed by the edges of the upper tier logs. In fact, it was a kind of canal that ran inside the wooden building and covered it from east and west. Their purpose will be discussed below. Oak was used to build the described pyramidal structure.

Around the "pyramid" at the ancient ground level, remains of a wooden planked decking with a thickness of 5-7 cm and a width of 2.2-3.8 m were discovered. Thus, the total diameter of the wooden structure (the tomb with the "pyramid" and the deck) was about

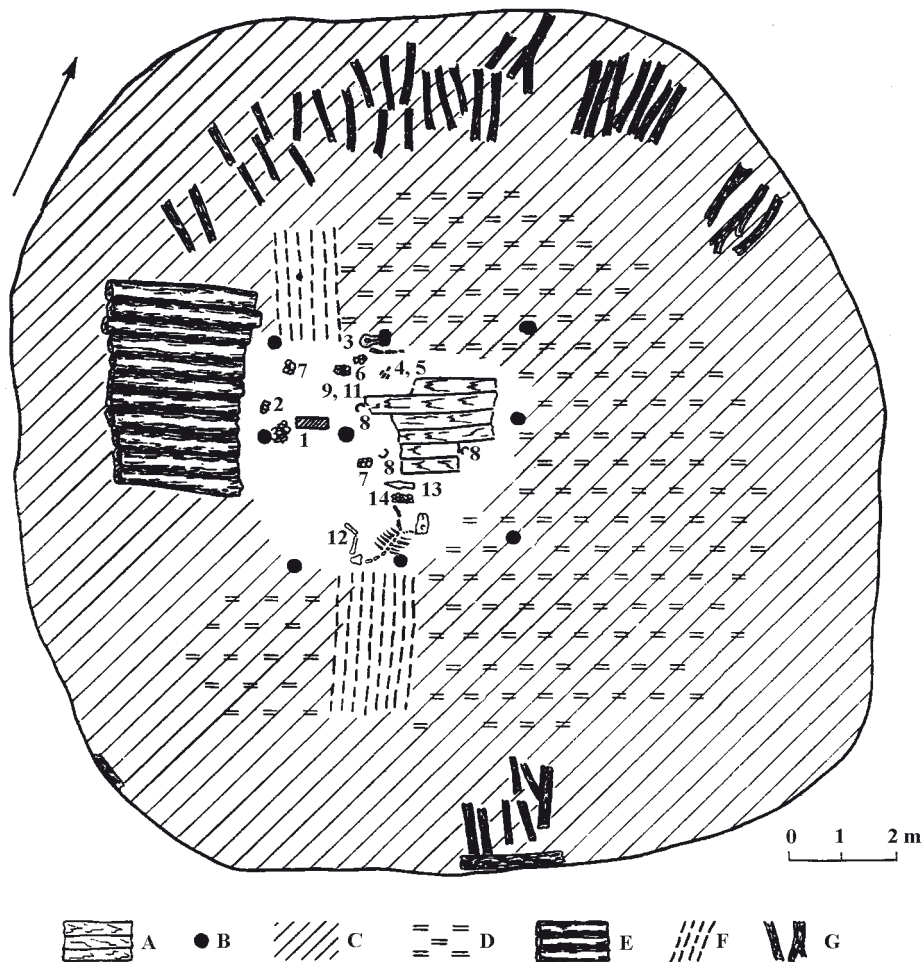

Fig. 7. Plan of the tomb from the barrow near the village of Mederove (by Bokii 1974): A – wooden flooring; B – pits for posts; C – burnt layer; D – red burnt layer; E – burnt decking; F – trace of wooden flooring; G – burnt wood. 1 – stone anthropomorphic stele; 2, fourteen amphora fragments; 3 – horse skull; 4 – sheep bones; 5 – iron knife; 6 – ceramics; 7 – armour fragments; 8 – iron staples; 9, 10 – rods; 11 – boar's tusk; 12 – horse skeleton; 13 – spearhead; 14 – fragments of amphora



19 m. In several places along the edge of the decking, the remains of wooden vertical columns with a diameter of 10-15 cm were preserved. On the western edge of the decking, there was a protruding convex segment that extended beyond its diameter. Here are recorded fragments of wooden logs placed horizontally, and another vertical column. The latter was not placed along the edge of the flooring, but closer to its centre. It is likely that a similar protruding segment had existed on the opposite side of the decking, on its eastern edge, as evidenced by individual details: vertical columns, including one placed closer to the middle of the mound, the remains of a horizontal fragment of a log. But this part of the site was destroyed by a trench dug during World War II, so it is impossible to reconstruct it reliably.

The wooden structure was partially burned. The southern, south-western and south-eastern sectors of the "pyramid" were significantly charred, and in some places traces of fire were recorded on the walls and ceiling of the tomb. In these sectors, a layer of clay was found above the charred structure, which was also affected by the action of fire and was burned. Interestingly, the thickness of the clay coating is uneven. Thus, on the sides of the "pyramid" built against the south wall of the tomb, the layer of clay did not exceed 15-20 cm, and around the south-western and south-eastern corners of the tomb it was quite thick, up to 1.0 m thick. In the profile of the central edge, it was noticeable that a layer of clay had entered the ceiling of the tomb on the south side, where it was partly baked and partly collapsed inside the tomb unbaked together with the ceiling.

In addition, on the slope of the "pyramid" in its southwestern corner, rounded features, 0.25-0.3 m in diameter, filled with embers from burnt wood, around which there was a ring of whitish ash, are clearly visible on the upper surface of the clay layer. The described filling is deepened through the layer of clay to the burnt timber under it. It can be assumed that these features are remnants of vents that led deep into the structure to the place of ignition of the structure. This area has traces of intense burning, which spread along the western sector of the "pyramid" through the artificial cavities-channels mentioned above. This, led to the failure of its top near the western wall of the tomb, measuring  $1.4 \times 2.3$  m to a depth of 0.6-0.7 m from the original height of the "pyramid". Near the opposite, north-eastern corner of the "pyramid" there is also a failure, around which the construction is well burned. In the area of the south-eastern corner of the "pyramid" a high intensity of burning was also recorded, a strip of burnt wood runs along the eastern wall of the tomb also through artificial cavities in the wooden construction. At the bottom of the slope in this place there are also visible spots of ash  $0.25 \times 0.4$  m,  $0.2 \times 0.3$  m. Probably, there were also vents, which are inconspicuous due to the greater burning of this sector.

The wooden structure did not burn down completely, but was charred in specific sectors of the pyramid. In many places, the layers of logs were charred through, but retained their integrity.

It is obvious that the described situation with features of burning of the tomb could develop as a result of purposeful actions of the barrow builders. It can be assumed that all

the preparatory work for the construction of the “pyramid” around the wooden tomb was necessary to implement a special technology for burning the wooden structure without air. This is a well-known issue in modern forest chemical production by the pyrolysis technique, which has its origins in antiquity and was used for the production of charcoal and tar (Gordon *et al.* 1988; Douglas Olson 1991). It is obvious that the builders of the Vasyne barrow, building a wooden “pyramid”, previously equipped a kind of firebox in the southern corners (the highest intensity of burning was recorded here), from which channels went into the thickness of the wooden construction along the western and eastern walls of the tomb. An additional layer of clay was also laid over the sites of the primary fires in the southern sector of the “pyramid”.

Given all of the above, it can be assumed that the combustion of the “pyramid” was carried out after the entire wooden structure was covered with a sufficiently thick layer of soil, which blocked air access. The air was supplied through the vents only in the places of conventional furnaces in the southern corners of the “pyramid” until the fire broke out. A discharge channel was also needed to provide draught. It is likely that it could have been installed near the north-eastern corner of the “pyramid”, where a sinkhole in the wooden construction was traced, surrounded by a section of burnt wood. After that, the open areas were also filled in. Only under such conditions was the wood in the structure baked through, and its structure was completely preserved.

The barrow above the wooden structure consisted of homogeneous chernozem, which was taken from the ground directly next to the barrow. Only in some places on the edge of the embankment were there loamy inclusions. In the profiles the borders of the lower edge of the mound construction are clearly visible all around the perimeter of the barrow (Fig. 3: 13).

The barrow was surrounded by a circular ditch with two causeways on the western and eastern sides. The width of the causeway is 3.8 m on the western sector and 4.2 m in the eastern sector. The above-described protruding segments of the wooden decking under the mound with vertical posts are oriented to the causeways. There is an impression of a certain compositional unity of these elements, which symbolized the passage to the burial space. The top of the ditch lies at the level of the top of the underlying natural loam. Given the contents of the barrow mound, we can assume that it was dug after removing the upper chernozem soil layer. The width of the ditch is 1.6-2.5 m, and it has a depth of 0.8-1.1 m. In cross section it has a trapezoidal shape, the bottom is flattened, the walls are concave, rarely straight. The width and depth of the moat, the shape of its walls differ in some areas. Thus, on the south, the moat has the greatest width (2.5 m) and depth (1.1 m). In the north it is narrower and shallower (2.1 and 0.8 m, respectively). In the south-eastern and south-western sectors, the width of the moat is only 1.6 and 1.7 m.

The evidence shows that the burial was accompanied by a ritual *trizna* (funeral feast), the remains of which (animal bones, fragments of amphorae and other pottery vessels) were found during excavations in the barrow at various depths, in the ditch, in the filling

of the wooden tomb. The ditch fill contained very few remains of the trizna ritual. Fragments of amphorae and animal bones were also found here at various depths, indicating that they entered the moat during its natural gradual filling with soil from the surface of the barrow. For example, the skull of a horse on the north side of the western causeway was at a depth of 15 cm from the upper section of the ditch fill. No finds were found at the bottom of the ditch, but on the southern side of the western causeway, there was a hollow of regular oval shape, measuring  $0.6 \times 1.2$  m, and 5-6 cm deep dug into the bottom of the ditch. Its purpose is unknown.

A significant amount of remains of the ritual trizna is concentrated within the square tomb in the central part of the barrow. It was filled with fragments of antique amphorae, among them are Chios amphorae with swollen neck, small fragments of thin-walled vessels in the black-figure style, bones of animals that fell inside the tomb together with the wooden ceiling. At a depth of 1.25-2.5 m remains of wooden trays (at least two) with sacrificial food and bronze and iron straps from them were found. These trays had originally been placed on the ceiling of the tomb, as the traces of charring were clearly discovered underneath a layer of scorched wood, on which the animal bones were found. In the southwestern sector of the tomb, at various depths (from 0.4 to 1.4 m), bones from a horse carcass were found. Remains of grass litter were found around its pelvic bones. Apparently, the horse was also laid on a grass litter onto the ceiling of the tomb, and then fell down with it inside its frame.

Residues of grains, which lay in a compact pile, were found near the horse's bones in the area of the southern wall of the wooden tomb, at a depth of 0.9 m (Fig. 13). The top wooden beam, next to which the grains were found, was partly burnt and partly charred (Fig. 12). In the previous publication, it was published as the remains of millet (Kozyr *et al.* 2019, 305, 306). According to S. Horbanenko (senior researcher at the Institute of Archaeology of the National Academy of Sciences of Ukraine), these were instead the seeds of the medicinal herb – gromwell (*Lithospermum officinale L.*). According to the conditions of the find, it is likely that these nuts were in a cup. Various parts of this plant have been used by people from ancient times for magical, religious and medicinal purposes. Gromwell is known for its useful properties as a medicinal and oilseed plant (Pashkevych and Chernovol 2021, 49, 50, 60; Andruschenko 2017, 14). We can assume that to some extent or another this find could be an illustration of the account by Herodotus about the burial of the Scythian nobility, which is accompanied by various herbs (Herodot 1993, IV, 71).

Within the tomb, closer to its western wall, the lower part of the anthropomorphic stele was discovered, which had apparently collapsed as a result of the natural destruction of the wooden ceiling.

The burial site had been completely looted in ancient times, probably by digging down through the mound's top and entering a gap in the tomb's lid. The skeleton of the deceased, as well as the funeral inventory, are missing. Little remained of the original contents. By the western wall of the tomb there was a partially destroyed skeleton of a dependent person,

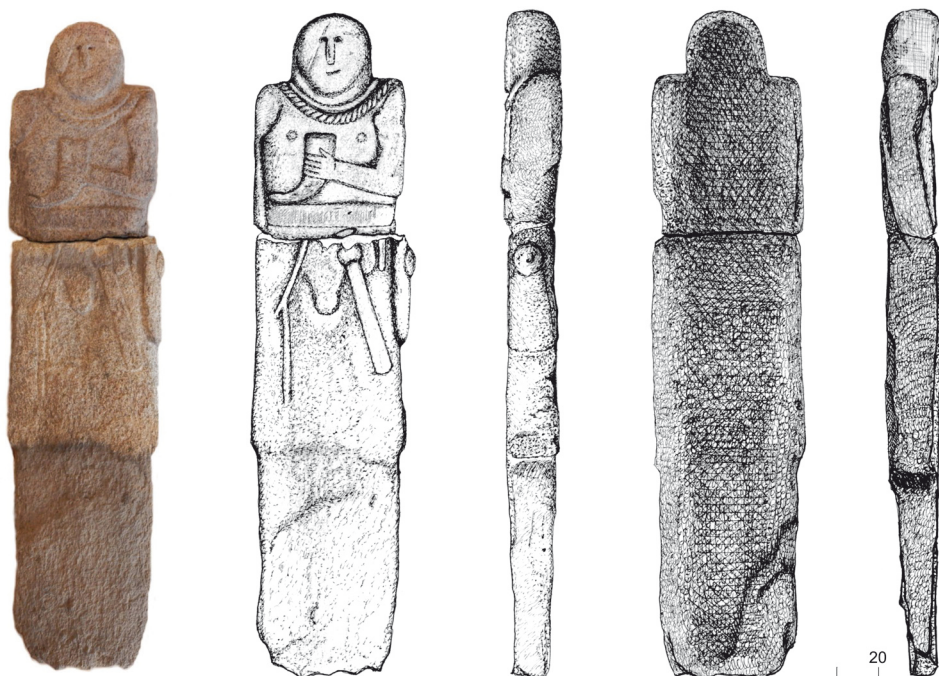

Fig. 8. Stone anthropomorphic stele from Vasyne Barrow 33

next to which a punch made of a horse's splint bone with a broken end was found. In some places in the south-western sector of the tomb, decay from a litter (straw mat?) was recorded. At the bottom of the tomb, at the level of the ancient ground level, near its northern wall, next to the supporting pillar, a bronze three-bladed arrowhead was found – the only item from the accompanying inventory that remained after the robbery. The absence of the skeleton and burial equipment may indicate a short period of time between burial and grave robbery. We assume that the skeleton was removed from the tomb when it still retained its anatomical integrity. As a result, nothing remained of the buried person.

The quantitative list of finds from the Vasyne barrow is therefore quite modest, but even what is left after the robbery of the grave is informative enough to determine the date of construction.

Undoubtedly, the most interesting and significant artefact is a stone anthropomorphic stele (Fig. 8). The sculpture is made of local grey granite by the method of adzing, engraving and grinding. The stele, 2.65 m high, is a massive image of a standing warrior. The lower end of the stele was isolated by a ledge and slightly narrowed down to form a spike-like projection. No remains of a base or any other devices for mounting the sculpture at the site of the find were found. Apparently, it was simply dug into the top of the barrow, and after the destruction of the wooden ceiling, part of it sank under its own weight into the tomb.

In its morphological type, the stele belongs to flat anthropomorphic sculptures with a fairly realistic image. Embossed faces, shoulders, arms, as well as individual details stand out. The head is circular with a high chin. The face is marked with eyes, a long straight nose and a mouth. The head smoothly passes into the neck, on which two torcs are shown, one of them is plain, the other one is twisted. The right arm is straight and pressed to the side of the torso, the left one is bent at the elbow and holds a rhyton in front of the chest. On the chest are marked elements of protective armour (?) in the form of two symmetrically placed rounded plates. In the lower part of the torso there is a belt, to which a sword and a whetstone are attached at the front in the area of the left thigh, and a whip in the area of the right. Also, a halyard is marked below the belt. On the left side of the stele there is a relief of a corytus fixed on a belt, decorated with a round umbo-shaped plate.

The set of things shown on the sculpture is characteristic for the images of the VI-V centuries BC. Some items are of particular interest. The long sword has a bar-shaped tip and a “kidney-shaped” crossguard; it is depicted in the sheath and attached to the belt with an elongated blade. Such swords are characteristic of the weapon kits of the second half of the VI century BC. However, they appear in the second half of the VII century BC (Meliukova 1964, 47). The element of fastening the sheaths to the belt resembles similar elements from complexes of Kelermes time (Meliukova 1964, fig. 17).

The image of the elements of protective armour on the chest in the form of two symmetrical hemispheres is recorded on three stelae from the Northern Black Sea Coast: Bilotserkivka (first half of the VI century BC) (Olkhovskiy and Evdokimov 1994, 30, 139, fig. 51), Vynohradivka (second half of VI – beginning of V century BC) (Olkhovskiy and Evdokimov 1994, 18, 94, fig. 6), Sibioara (first half of VI century BC) (Olkhovskiy and Evdokimov 1994, 17, 89, fig. 1). Two more stelae with images of such elements were found in the Caucasus – Zamni-Yuart (VI century BC) (Olkhovskiy and Evdokimov 1994, 37; 171, fig. 83) and Vorvorovskoliska (end of VII – beginning of VI centuries BC) (Olkhovskiy and Evdokimov 1994, 35, 126, fig. 76). It is assumed that the same domed plates in Scythian times could be sewn on leather armour for additional protection of the soldier (Olkhovskiy and Evdokimov 1994, 72; Chernenko 1968, 17, 18).

The image of a round umbo-shaped plate on a corytus is also quite interesting. Decoration of a corytus with such plates was recorded in the Urals in burials of the second half of the V-IV centuries BC from the Barrow No. 4 of the Filipovsky Grave (Yablonsky 2008, 202; 2009, 419, 421). According to Olkhovskiy, umbo-shaped plates of truncated-conical and rounded shape are a characteristic feature of corytus quivers of the V-IV centuries BC. In turn, the time of the advent of these plates was determined by the researcher to have occurred at the turn of the VI-V centuries BC (Olkhovskiy and Evdokimov 1994, 73). The closest analogy is the image of a similar plate on a sculpture with a broken head in the Kirovohrad Regional Museum of Local Lore (the exact location is unknown), which dates from the second half of VI – early V century BC. It should be noted that this analogy is quite similar to the iconography as a whole. Thus, the rhyton is depicted in the left hand,

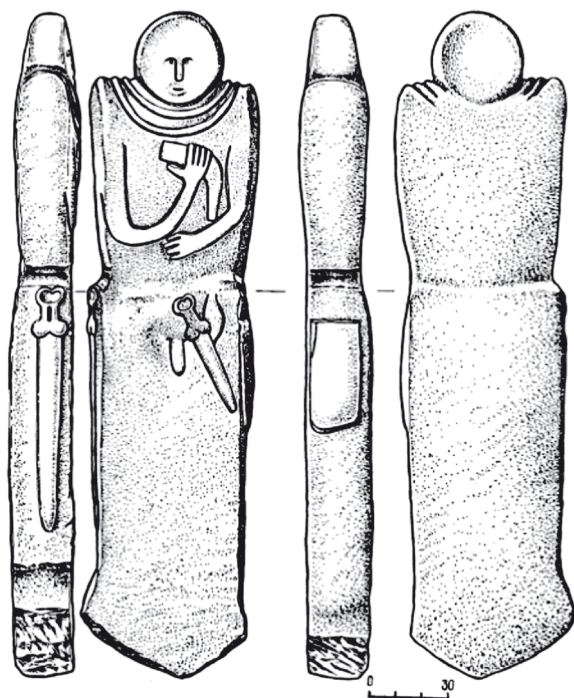

Fig. 9. Stone anthropomorphic stele from the barrow near the village of Mederove (by Olkhovskiy and Evdokimov 1994)

there are two tores, a belt and a whip, identified male features, but there is no whetstone. The assemblage of items on the Kirovohrad Museum is supplemented by a sword on the right side, and the warrior himself is depicted dressed in a kaftan, a long scythe is marked on his back (Bokii and Mohylov 2014, fig. 16; Gorbul and Bokii 1987, 49; Olkhovskiy and Evdokimov 1994, fig. 43).

Also close to Vasyne in iconography is a stele from the barrow near the village of Mederove (Fig. 9). The statue has a similar set of items – two tores, a rhyton, a belt, two swords, a quiver and an image of a halyard. The facial features of both stelae are very similar, in particular, the close-set eyes. However, the head of the Mederove statue is more rounded, as if “sunk” in the shoulders, the neck is not isolated, the tip of the nose and mouth are below shoulder level. Both tores on the neck are plain and here are no rounded plaques on the chest. The narrower belt is clearly seen only in places. The arms are folded in a different position – the right holds a rhyton, and the left one is placed on the abdomen. The warrior’s set does not include a whip or a whetstone, but an additional sword is marked on the right side. The swords on the statue from Mederove have a volute-shaped top and a kidney-shaped crossguard (Bokii 1974, fig. 2).

It is also important that both analogies are geographically close to our stele. In fact, Mederove village is located 5 km from Vasyne village, and the stele from the Kirovohrad Regional Museum of Local Lore has long been interpreted as having been found in the Melhunovskiy barrow (Gorbul and Bokii 1987, 48).

The suite of objects depicted on the stele allows us to determine the time of its creation at the turn of the VI-V centuries BC. The iconographic and morphological features of other Scythian sculptural images of this time do not contradict this date (Olkhovskiy and Evdokimov 1994, 46-60).

However, a more accurate date was given for the burial by finds of ancient ceramic vessels from the mound. The Chios amphorae are represented by wall fragments and necks with fragments of handles (Fig. 10: 8-10). All vessels were made of light clay, the fabric was well mixed with finely ground impurities of lime and mica. The firing is uniform, in some places the central part of the sherd is lighter in colour at the thickening of the walls and at the end of the handles. The vessels belong to the Chios amphorae of Type III – with swollen neck (early swollen-neck variant III-A, according to the classification of S. Monakhov). Similar amphorae appear in the Northern Black Sea region in the last third of the VI century BC and are present here in the first quarter of the V century BC (Bessonova and Skoryi 2001, 78, fig. 51: 3; Buisykh *et al.* 2018, 148, 149, fig. 2: 2; Monakhov 1999, 57; 59, fig. 9: 1-4). Later amphorae of this variant have more elongated proportions of the necks (Monakhov 2003, 16, 17).

The most important thing for dating is the fragments of an Attic black-figure kylix (Fig. 10: 1-7). This belongs to the products of the masters of the group “Leafless Group” and dates from 500-480 BC (Beazley 1956, 632-653; Boardman 1974, 150, 151). Similar elements of the images are found in the bowls of Athens (Burow 1980, pl. 31: 1-4, 32: 1-4; Beazley 1956, pl. 642: 139, 716: 66; Freyer-Schanenburg eds 1988, pl. 27: 5).

The bronze arrowhead is also a chronological indicator. It belongs to the so-called basic type (Fig. 11: 1). It is three-bladed with a hidden sleeve, height – 1.4 cm, base width – 1.3 cm. Such tips appear in the “mixed” complexes of the second half of the VI century BC, containing both Kelermes and Middle Scythian products (Mohylov and Didenko 2009, fig. 7). In early Middle Scythian burials, they dominate numerically (Polin 1987, fig. 4). In the steppe region, in particular, the same arrows were found in Burial 1 of Barrow 6 near the village of Oleskandrivka dated to the VI-V centuries BC (Kovaleva and Mukhopad 1982, 95, fig. 4: e), in a barrow near the village of Novokiyivka in the V century BC (Evdokimov and Murzin 1984, 77, fig. 2: 6). In the forest-steppe on the Right Bank of the Dnipro, similar artefacts have been found in the burials of Barrow 52 near the village of Kovali and Barrow 467 near Turia (Petrenko 1967, vol. 34: 133, 134), near Hryshentsi (Galanyna 1977, tab. 31: 32). On the Left Bank – similar items were found in the barrows near the village of Basivki (Ilinskaya 1968, vol. 27), Barrows 9 and 478 near the village of Vovkivtsi (Ilinskaya 1968, vol. 35: 13, 39: 14; Galanina 1977, pl. 23: 26), Barrow 13 in the tract of Staikin Verkh (Ilinskaya 1968, vol. 10: 24-25), in Barrow 5 of the Protopopivsky burial



Fig. 10. Ancient Greek pottery from Vasyne Barrow 33:  
1-7 – fragments of a black-figure kylix, 8-10 – fragments of Chios amphorae



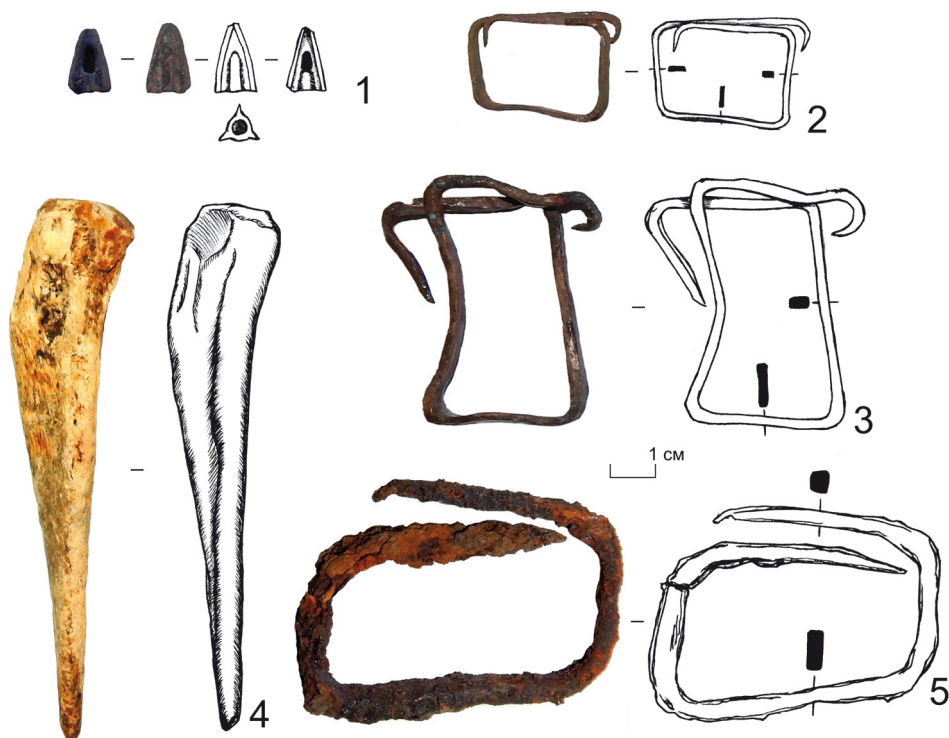

Fig. 11. Finds from Vasyne Barrow 33:  
1 – bronze arrowhead, 2-3 – bronze staples, 4 – bone pin, 5 – iron bracket



Fig. 12. Residues of "nuts" of *Lithospermum officinale* L. (photo by Serhii Horbanenko)

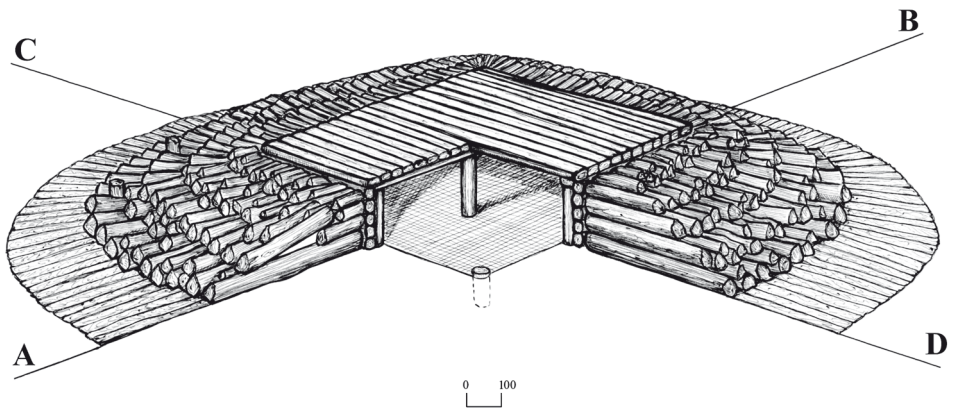

Fig. 13. Reconstruction of the wooden burial structure from Vasyne Barrow 33

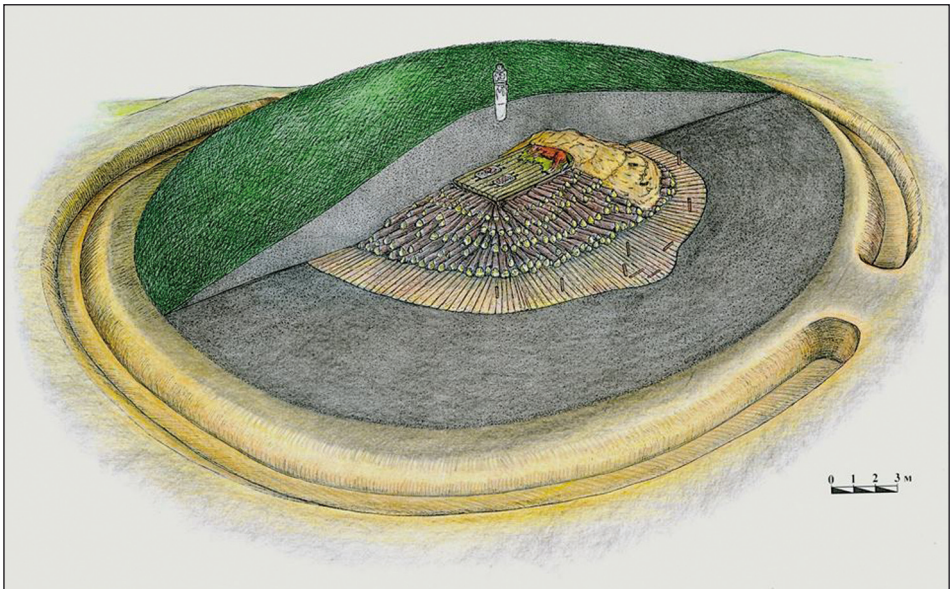

Fig. 14. Reconstruction of Vasyne Barrow 33

ground (Babenko 2007, 35, fig. 2: 30) and in Burial 1 of Barrow 1/2013 of the Skorobor burial ground (Shramko 2016, 272, fig. 1).

Thus, the finds from the Vasyne barrow have numerous analogies in the complexes of the beginning of the Middle Scythian stage. But nothing like a burnt wooden pyramid-shaped burial structure around the tomb has yet been discovered. In general, the type of ground-level wooden chamber tombs is one of the rare types of burial structures of Scythian

times. Generally, they are preserved in a rather dilapidated condition due to the use of fire in the funeral rite. In the region of the Dnipro Right Bank, only a few Scythian monuments with ground-level wooden tombs can be named. In particular, in the steppe the remains of such a tomb were recorded in a barrow near Kryvyi Rih on the Kalytva River. However, its construction is unknown, only traces of burnt wood and baked soil were found under the barrow (Murzin 1982, 50; 1984, 50). Other steppe wooden tombs were built in pits (Olkhovskiy 1991, 42). In the forest-steppe Right Bank, in the basin of the Tyasmin River, the remains of wooden earthen tombs were excavated in barrows of early Scythian times – Barrow 49 near Gulyai-Horod and Barrow 220 on the river Tenetyuka. The details of their construction are also unknown to us, as they were almost completely burned in antiquity (Kovpanenko *et al.* 1989, 29-31; Ilinskaya 1975, 19, 20).

Also, the remains of massive wooden ground-level structures were discovered in the burial mounds of Butory-I on the left bank of the Dnister. Unlike the tomb in Vasyne, they were not separate burial structures. There are probably the remains of a grandiose ceiling over the graves. It is also worth noting that there are no support columns in their construction. These mounds (Nos 2, 5, 10, 13 and 16) are dated to the 4<sup>th</sup> century BC (Sinika *et al.* 2013, 48, 49, 63-65, 73-75, 79, 80, 86, 87).

On the border of the forest-steppe and steppe on the right bank of the Dnipro River, there are mounds under which the remains of wooden tombs have been excavated. Unfortunately, they were all destroyed, and therefore do not allow us to draw analogies. This concerns a mound near the village of Kutsevolivka (Bokii and Olkhovskiy 1994), a mound near the village of Zaschita (Bokii 1970), and also in Mound 10 near the village Pokazhove (Bokii 1994, 108-110).

The closest in cultural and territorial terms to the described monument is the already mentioned barrow of the beginning of the V century BC near the village of Mederove, excavated in 1964 by an expedition led by A. I. Terenozhkin and published by N. M. Bokii (Bokii 1974). At the time of research, its height was 3.5-4 m, and its diameter was 40 m. Under the mound, there were the remains of a nine-column chamber tomb of rectangular shape, measuring 5.5 × 4.5 m, built on the level of the ancient ground surface. Detailed features and structural elements of the wooden structure are not known, as it was burned in ancient times. Only in the southwestern sector of the mound were fragments excavated of massive wooden logs, 0.25-0.3 m in diameter, laid in a row perpendicular to the tomb wall. In some places, burnt and rotten logs were recorded, lying radially to the centre of the structure (Fig. 7). The ritual hearth had a diameter of about 15 m, and as a result of the fire, the soil at the base of the tomb was baked in some places to a depth of 0.3 m within the tomb, in addition to accompanying objects in the burial, a stone statue of a Scythian warrior made of red granite was found (Bokii 1974, 264). The remains of massive logs and the scale of the hearth indicate the significant size of the original structure. It was quite massive, perhaps even something similar to the one found in the barrow near the village of Vasyne. In both cases, ground-based wooden pillar tombs were used for burial. The simi-

larity of the size of the tomb itself, its orientation, wooden logs laid perpendicular to the walls, and the use of fire in the funeral rite are striking. However, there are significant differences. In the Mederivskiy mound, the logs were laid in a single row near the tomb wall. The authors of the excavations call them a flooring. Around this flooring were tree trunks lying radially (Bokii 1974, 264). The technology of burning a wooden structure was also significantly different, since the tomb of the Mederovskiy barrow was almost completely burned down, and the ancient ground surface was heavily baked.

As already mentioned, both mounds are located at a close distance, have similar features of funerary structures and rites. The iconographic similarity of the stone anthropomorphic stelae is also striking. The time of construction of the barrows is also close. It should be noted that the burial structure studied in Barrow near the village of Vasyne is distinguished by its scale and strength. The special pyramidal structure in the core of the mound is a kind of variant of chamber tombs of Scythian times, which as yet has no direct analogies.

The combination of finds from the barrow near the village of Vasyne and the images on the stele allow us to date the burial in a ground level chamber tomb to the beginning to the first quarter of the V century BC.

The materials of the monument also make it possible to determine the cultural and ethnic attribution of the complex. In the mound near the village of Vasyne, there are seven of the nomadic features identified for the Scythian period by S. Skoryi (Skoryi 2003, 53) burial in a barrow with a ditch built around it; 2) a ground-level wooden structure; 3) the use of fire in the ritual; 4) the remains of a plant mat in the chamber; 5) the remains of meat ritual food; 6) the skeleton of a slave was found in the grave; 7) a stone anthropomorphic statue. Taken together, these features allow us to classify the Vasyne barrow as a purely Scythian steppe monument. It is obvious that a member of Scythian military aristocracy was buried here.

## References

- Andruschenko O. 2017. Perspektivyv kulturyvuvannia *Lithospermum officinale* L. *Ahrobioriznomanitia dla pokraschennia kharchuvannia, zdorovia ta yakosti zhyttia*, 14-17.
- Babenko L. I. 2007. Predmety ozbroennia ta viyskovoho sporiadzhennia u pokhovanniakh Protopyvskoho kurhannoho mohylnya. *Kharkovskiy arkheologicheskyy sbornik* 2, 30-39.
- Burow J. eds 1980. *Corpus Vasorum Antiquorum: Deutschland. Tübingen* (= *Antikensammlung des archäologischen Instituts der Universität* 3). München: Union académique internationale.
- Bessonova S. S. and Skoryi S. A. 2001. *Motroninskoe gorodische skifskoy epokhi (po materialam raskopok 1988–1996 gg.)*. Kiev, Krakov: Institut Arkheologii NANU, Institut Arkheologii Yagelonskogo universiteta.
- Beazley J. D. 1956. *Attic Black-figure vase-painters*. Oxford: Clarendon Press.

- Boardman J. 1974. *Athenian black-figure vases*. London: Thames and Hudson.
- Bokii N. M. 1970. Novi pamiatky skifskoho zvirynoho stylu z Kirovohradschyny. *Arkheolohiya* 23, 182-189.
- Bokii N. M. 1974. Skifskiy kurgan u sela Mederevo. *Sovetskaya arkheologiya* 4, 264-271.
- Bokii N. M. 1994. Skifski pamiatky baseynu r. Syniukhy. *Naukovi zapysky z istorii Ukrainy*, 107-114.
- Bokii N. M. and Mogilov A. D. 2014. Novoe o Melgunovskom kurgane. *Naukovi zapysky. Seriya: Istorychni nauky. Aktualni problemy arkheolohii ta istorii rannoho zaliznogo viku* 21, 26-51.
- Bokii N. M. and Olkhovskiy V. S. 1994. Ranneskifskiy kurgan na Dneprovskom Pravoberezhze. *Rossiyskaya arkheologiya* 2, 151-163.
- Buiskykh A. V., Fornase Y. and Kuzmischev O. H. 2018. Doslidzhennia Olviyskoho peredmistia bilia zakhidnykh vorit. *Arkheolohichni doslidzhennia v Ukraini 2016*, 146-149.
- Chernenko E. V. 1968. *Skifskiy dospekh*. Kiev: Naukova dumka.
- Douglas Olson S. 1991. Firewood and Charcoal in Classical Athens. *Hesperia: The Journal of the American School of Classical Studies at Athens* 60/3, 411-420.
- Evdokimov G. L. and Murzin V. Yu. 1984. Ranneskifskoe pogrebene s oruzhem iz Khersonskoy oblasti. In E. V. Chernenko (ed.), *Vooruzhenie skifov i sarmatov*. Kiev: Naukova Dumka, 75-82.
- Freyer-Schanenburg B. (eds) 1988. *Corpus Vasorum Antiquorum: Deutschland. Kiel: Kunsthalle, Antikensammlung 1 (= Corpus Vasorum Antiquorum 55)*. München: C.H. Beck.
- Galanina L. K. 1977. *Skifskoe drevnosti Podneprovia (Ermitazhnaya kolleksiya N. E. Brandenbura)* (= Svod arkheologicheskikh istochnikov D 1-33). Moskva: Nauka.
- Gorbul G. P. and Bokii N. M. 1987. O skifskikh stelakh Kirovogradskogo kraevedcheskogo muzeya. In *Kimmeriytsy i Skify. Tezisy dokladov Vsesoyuznogo seminara, posviaschennogo pamiaty A. I. Terenozhkina*. Kirovograd, 48-50.
- Gordon L. V., Skvortsov S. O. and Lisov V. I. 1988. *Tekhnologiya i oborudovane lesokhimicheskikh proizvodstv*. Moskva: Lesnaya promyshlennost.
- Herodot. 1993. *Istoriya v deviaty knihakh. Knzha IV*. A. O. Biletskyi (ed., tran.). Kyiv: Naukova dumka.
- Ilinskaya V. A. 1975. *Ranneskifskie kurgany basseyna r. Tyasmin (VII-VI vv. do n.e.)*. Kiev: Naukova dumka.
- Ilinskaya V. A. 1968. *Skify Dneprovskogo lesostepnogo Levoberezhia (kurgany Posulia)*. Kiev: Naukova dumka.
- Kovaleva I. F. and Mukhopad, S. E. 1982. Skifskoe pogrebene kontsa VI-V vv. do n.e. u s. Aleksandrova. In A. I. Terenozhkin (ed.), *Drevnosti stepnoy Skifii*. Kiev: Naukova Dumka, 91-102.
- Kovpanenko G. T., Bessonova S. S. and Skoryi S. A. 1989. *Pamiatniki skifskoy epokhi Dneprovskogo lesostepnogo Pravoberezhia (Kievo-Cherkasskiy region)*. Kiev: Naukova dumka.
- Kozyr I. A., Panchenko K. I. and Chornyi O. V. 2019. Vasynskiy kurhan serednoskifskoho chasu. *Arkheolohiya i davnia istoriya Ukrayiny* 2(31), 300-314.
- Kryvulchenko A. I. 2011. *Vodni obekty Kirovogradskoy oblasti*. Kirovograd: Imeks-LTD.
- Meliukova A. I. 1964. *Vooruzhenie skifov (= Svod arkheologicheskikh istochnikov D 1-4)*. Moskva: Nauka.
- Mohylov O. D. and Didenko S. V. 2009. Skifskiy kurhan 448 bilia s. Zhuravka – pamiatka perekhidnogo chasu v Potiasmyzni. *Arkheolohiya* 3, 45-55.

- Monakhov S. Yu. 1999. *Grecheske amfory v Prichernomore. Kompleksy keramicheskoy tary VII-II vekov do n.e.* Saratov: Saratovskiy natsionalnyi issledovatel'skiy gosudarstvennyi universitet im. N. G. Chernyshevskogo.
- Monakhov S. Yu. 2003. *Grecheske amfory v Prichernomore. Tipologiya amfor veduschikh tsentrov-eksporterov tovarov v keramicheskoy tare.* Katalog-opredelitel. Moskva, Saratov: Izdatelstvo "Kimmerida", Izdatelstvo saratovskogo universiteta.
- Murzin V. Yu. 1984. *Skifskaya arkhayka Severnogo Prichernomia.* Kiev: Naukova dumka.
- Murzin V. Yu. 1982. Pogrebalnyi obriad stepnykh Skifov v VII-V vv. do n.e. In A. I. Terenozhkin (ed.), *Drevnosti stepnoy Skifii.* Kiev: Naukova dumka, 47-64.
- Olkhovskiy V. S. 1991. *Pogrebalno-pominalnaya obriadnost naseleniya Stepnoy Skifii (VII-III vv. do n.e.).* Moskva: Nauka.
- Olkhovskiy V. S. and Evdokimov G. L. 1994. *Skifske izvayaniya VII-III vv. do n.e.* Moskva: IA RAN.
- Pashkevych H. O., Chernovol D. K. 2021. Znakhidky horishkiv horobeynyka na arkheolohichnykh pamiatkakh Ukrainy. *Arkheolohiya* 3, 47-60.
- Petrenko V. G. 1967. *Pravoberezhze Srednego Pridneprovya v V-III vv. do n.e. (= Svod arkheologicheskikh istochnikov D 1-4).* Moskva: Nauka.
- Polin S. V. 1987. Khronolohiya rannoskifskiykh pamiatok. *Arkheolohiya* 59, 17-36.
- Shramko I. B. 2016. Kolchanniy nabor iz pogrebeniya kontsa VI v. do n.e. mogilnika Skorobor. *Arkheolohiya i davnia istoriya Ukrayiny* 2(19), 270-279.
- Sinika V. S., Razumov S. N. and Telnov N. P. 2013. *Kurgany u sela Butory (= Arkheologicheske pamiatniki Pridnestrovia 1).* Tiraspol: Pridnestrovskiy gosudarstvennyi universitet im. T. G. Shevchenko.
- Skoryi S. A. 2003. *Skify v Dneprovskoy Pravoberezhnoy lesostepi (problema vydeleniya iranskogo etnokultrnogo elementa).* Kiev: Institut arkheologii NANU.
- Yablonskiy L. T. 2008. Novye materialy k probleme formirovaniya kultury rannikh kochevnikov Yuzhnogo Priuralia. In L. T. Yablonskiy (ed.), *Voprosy arkheologii Urala: sbornik nauchnykh trudov.* Ekaterinburg: Uralskiy gosudarstvennyi universitet Magellan, 194-207.
- Yablonskiy L. T. 2009. Umbonoobraznye zolotye predmety skifskogo vremeni iz Filipovki. In S. S. Besonova (ed.), *Epokha rannego zheleza. Sbornik nauchnykh trudov k 60-letiu S. A. Skorogo.* Kiev, Poltava: Institut arkheologii NANU, 418-425.